

Cash Acme™

HG110-HX Thermostatic Mixing Valve

The Heatguard™ 110-HX is a temperature actuated mixing valve that mixes hot water with cold water to deliver tempered water at a reduced temperature.

Application

Hydronic and radiant heating systems.

Specification Data

Performance

Adj. Outlet Temperature Range	85°F-176°F (29°C-80°C)
Factory Set Temperature Range	115°F-120°F (46°C-49°C)
Hot Supply Temperature	120°F-180°F (48.9°C-82.2°C)
Cold Supply Temperature	39°F-80°F (3.9°C-26.7°C)
Maximum Pressure	230 psi
Min. Flow Rate	1 GPM
Max. Flow Rate @ 45 psi	20 GPM

Materials

Body	Lead-Free ¹ DZR Brass
Springs	Stainless Steel
Internal Cap	Brass
Piston	Engineered Polymer
Inlet Strainer Screens	Stainless Steel

¹ Lead Free for all models. Surfaces that are in contact with consumable water contain less than 0.25% lead by weight.

Certifications & Listings

NSF/ANSI/CAN 61, ASSE 1017, NSF/ANSI/CAN 372, CSA 125.3



Refer to local plumbing code

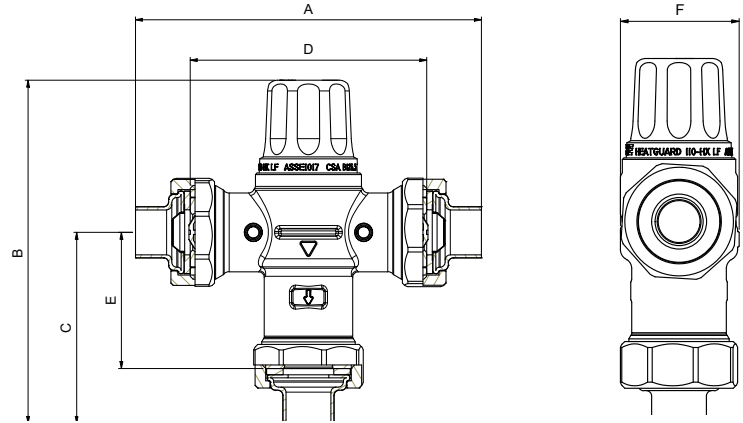

Dimensions (inches)

Size	Connection Style	Part #	A	B	C	D	E	F
1/2"	Sweat	24513	4-27/32	5	2-43/64	3-5/16	1-29/32	1-33/64
1/2"	Threaded NPT	24517	5-11/16	5-13/32	3-3/32	3-5/16	1-29/32	1-33/64
1/2"	Cold Expansion	25947	5-35/64	5-5/32	3-1/32	3-5/16	1-29/32	1-33/64
3/4"	Sweat	24514	5-15/64	5-3/16	2-7/8	3-5/16	1-29/32	1-33/64
3/4"	Threaded NPT	24518	6-3/16	5-21/32	3-11/32	3-5/16	1-29/32	1-33/64
3/4"	Cold Expansion	25983	6-1/64	5-3/8	3-17/64	3-5/16	1-29/32	1-33/64
3/4"	SharkBite	24867	6-13/64	5-23/32	3-21/32	3-5/16	1-29/32	1-33/64
1"	Sweat	24515	7-9/16	6-21/64	4-3/64	3-5/16	1-29/32	1-33/64

Flow Curve

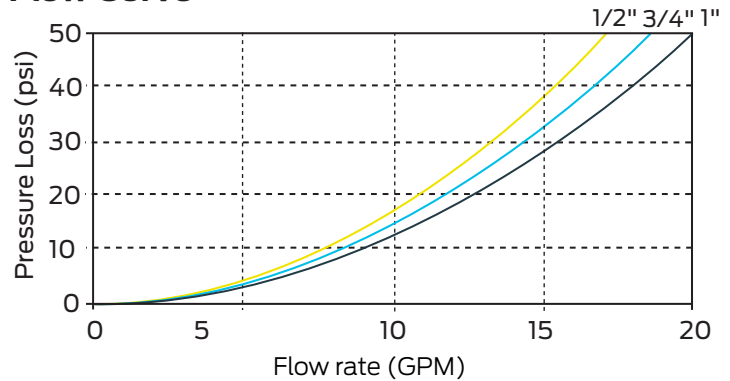

Product Submittal

Name	
Date	
Architect/Owner	
Contractor	
Tag	
Notes	