

## Wave Optics Using Microwaves

### DEMONSTRATE AND INVESTIGATE THE PHENOMENA OF INTERFERENCE, DIFFRACTION AND POLARISATION USING MICROWAVES

- Take point-by-point measurements of the intensity when microwaves are diffracted at a pair of slits
- Determine the positions of the maxima for different diffraction orders
- Determine the wavelength when the distance between the slits is known
- Investigate the polarisation of the emitted microwaves and modify it

UE3060300

03/18 UD

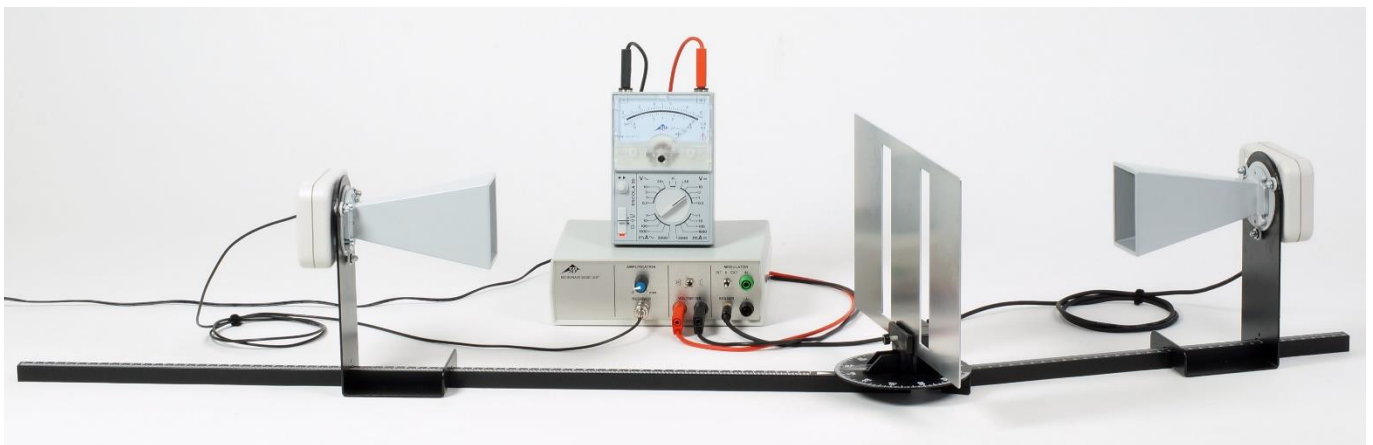

Fig. 1: Measurement configuration for diffraction of microwaves at a pair of slits

### GENERAL PRINCIPLES

In wave optics light is regarded as consisting of transverse electromagnetic waves. This explains the phenomena of interference, diffraction and polarisation. Microwaves too are electromagnetic waves and they exhibit the same phenomena, but the wavelengths are much greater than those of visible light. Consequently, wave optics experiments can also be carried out using microwaves with diffraction objects and polarisation grids, the internal structure of which is obvious to the unaided eye.

This experiment investigates the diffraction of microwaves of wavelength  $\lambda$  at a pair of slits separated by a distance  $d$  of several centimetres. Measure the characteristic intensity distribution for diffraction by a pair of slits (see Fig. 5), with maxima at the angles  $\alpha_m$  satisfying the condition:

$$(1) \quad \sin \alpha_m = m \cdot \frac{\lambda}{d}, \quad m = 0, \pm 1, \pm 2, \dots$$

Evidently the maximum intensity is observed when the detector is positioned exactly behind the central strip between the slits ( $\alpha = 0, m = 0$ ), where it could not have detected radiation travelling along a straight-line path from the transmitter. This phenomenon can be explained as the result of interference between the partial wave beams from the two slits and is clear evidence for the wave nature of the microwaves.

By rotating the detector about the direction of the source, clear evidence for the linear polarisation of the emitted microwaves can be obtained. When the planes of the transmitter and the detector are crossed at  $90^\circ$  the observed intensity falls to zero. If one of the polarising grids is then placed in the beam at an orientation of  $45^\circ$  to the other, the detector again detects radiation, although with a smaller amplitude than before. The grid transmits that component of the electric field vector of the incoming microwaves that vibrates parallel to the direction of the polarising grid. In this way the component vibrating in the direction parallel to the plane of the detector can be measured.

## LIST OF EQUIPMENT

1	Microwave Set 9,4 GHz @230V	1009951 (U8493600-230)
or		
1	Microwave Set 10,5 GHz @115V	1009950 (U8493600-115)
1	Analogue Multimeter Escola 30	1013526 (U8557330)
1	Pair of Safety Experimental Leads, 75 cm, red/blue	1017718 (U13816)

## SET-UP

- Insert the short rail onto the long rail (Fig. 2).
- Set the rail system up in the  $0^\circ$  position (Fig. 3).
- Attach the plate holder to the disc with the angle scale as shown in Fig. 3 and secure it in place with the grub screw
- Attach the transmitter at 170 mm on the short rail and the receiver at 400 mm on the long rail. The transmitter and receiver should be aligned such that they are horizontal and parallel to one another.
- Connect the transmitter to the "Transmitter" socket and the receiver to the "Receiver" socket on the control unit
- Connect the analogue multimeter to the 4-mm "Voltmeter" socket and select a measuring range of 3 V DC.

The analogue multimeter shows the amplified signal from the receiver as a DC voltage proportional to the signal level (when modulation is switched off).

- Turn off the speaker and set the "Modulator" to "0".
- Connect the control unit to the mains with the plug-in power supply provided. It will then immediately be ready to use.
- Turn the "Amplification" controller for signal amplification until the analogue multimeter displays a maximum voltage of 3 V.

## EXPERIMENT PROCEDURE

### Diffraction by a double slit

- Move the transmitter to position 250 mm. Align the transmitter and receiver such that they are vertical and parallel to one another.
- Put the plate with the double slit in the middle of the slot in the plate holder and clamp it in place with the fastening screw.

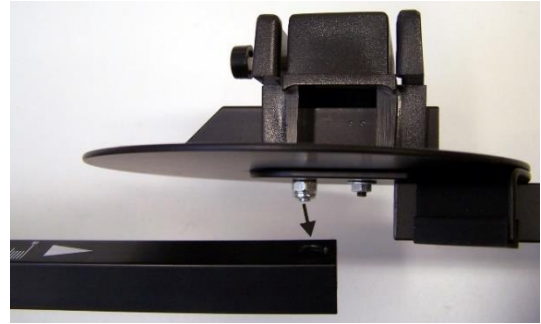

Fig. 2: Insert short rail into long rail

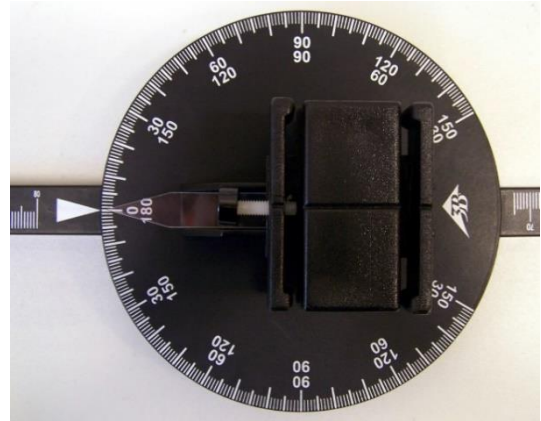

Fig. 3:  $0^\circ$  position for rail system

### Note

Standing waves form between the transmitter and the plate with the double slit.

- Move the transmitter slightly to the left or right until the analogue multimeter displays a voltage maximum.
- Adjust the signal gain for the receiver to make the analogue multimeter again display 3 V.
- Use one hand to hold the long rail and receiver still while using the other hand to turn the short rail with the receiver anti-clockwise until the pointer at the end of the long rail coincides with the  $65^\circ$  mark on the disc with the angle scale. Hold the transmitter firm so that it does not change position along the rail. Enter this angle into Table 1 as  $-65^\circ$ .
- Read off the voltage from the analogue multimeter and enter the value into Table 1.
- Repeat the measurement in steps of  $2.5^\circ$  until the rails reach  $0^\circ$  and then continue until they are at  $+65^\circ$ . Do this by turning the short rail with the transmitter anti-clockwise. Enter all the values into Table 1.

### Polarisation

- Return the set-up to its initial configuration (see "Set-up").
- Align the transmitter receiver and polarisation grating as shown in Figs. 4a – f. In each case observe the analogue multimeter and make a note of what you see.

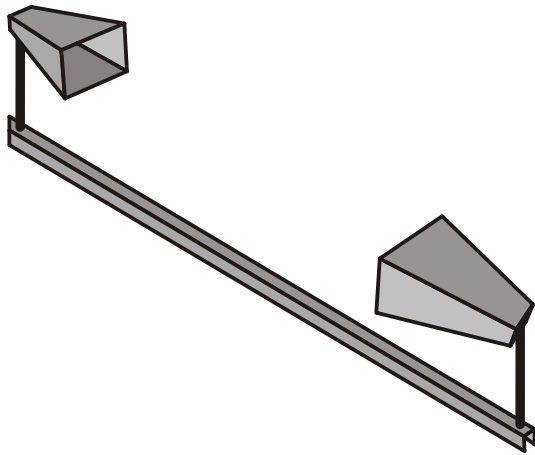

Fig. 4a: Parallel alignment of transmitter and receiver

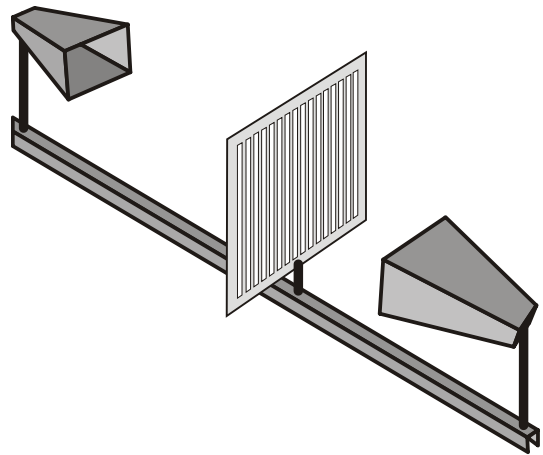

Fig. 4d: Vertical alignment of polarisation grating between transmitter and receiver aligned horizontally and parallel to one another

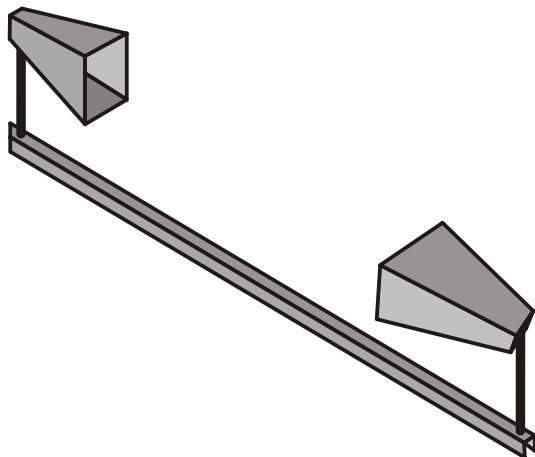

Fig. 4b: Orthogonal alignment of transmitter and receiver

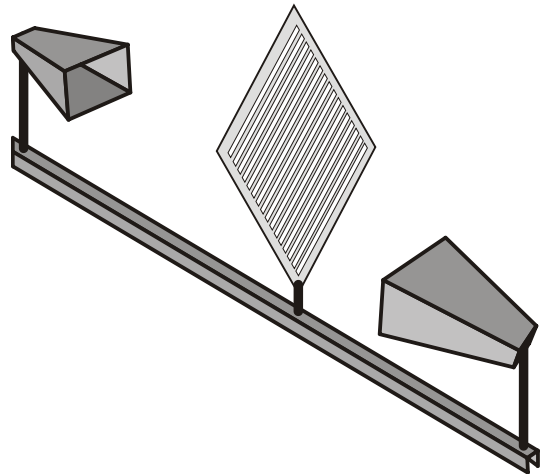

Fig. 4e: Diagonal alignment of polarisation grating between transmitter and receiver aligned horizontally and parallel to one another

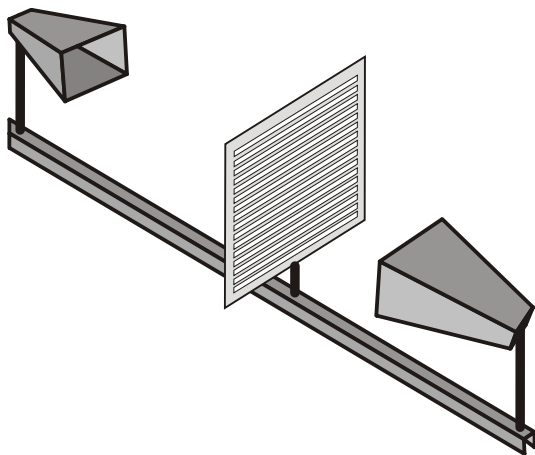

Fig. 4c: Horizontal alignment of polarisation grating between transmitter and receiver aligned horizontally and parallel to one another

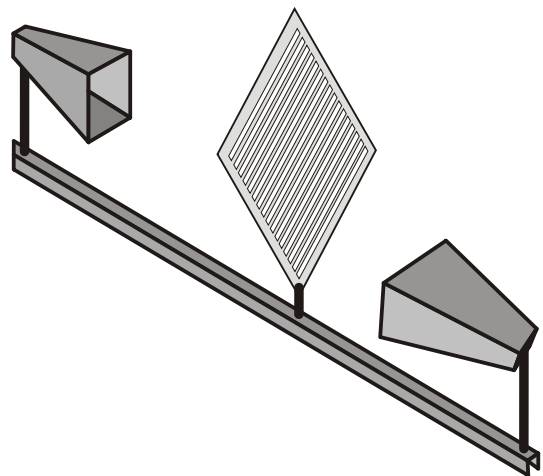

Fig. 4f: Diagonal alignment of polarisation grating between transmitter and receiver aligned orthogonally and parallel to one another

### SAMPLE MEASUREMENT

Tab. 1: Diffraction of microwaves by a double slit. Measured voltages as a function of rotation angle

$\alpha$	$U/V$	$\alpha$	$U/V$	$\alpha$	$U/V$
-65.0°	0.40	-20.0°	2.90	25.0°	1.00
-62.5°	0.65	-17.5°	2.85	27.5°	0.30
-60.0°	1.10	-15.0°	2.25	30.0°	0.45
-57.5°	0.90	-12.5°	1.65	32.5°	1.00
-55.0°	0.70	-10.0°	0.35	35.0°	1.40
-52.5°	0.60	-7.5°	0.55	37.5°	1.85
-50.0°	0.70	-5.0°	1.75	40.0°	2.10
-47.5°	1.00	-2.5°	2.75	42.5°	1.75
-45.0°	1.50	0.0°	2.95	45.0°	1.10
-42.5°	2.00	2.5°	2.55	47.5°	0.75
-40.0°	2.25	5.0°	1.65	50.0°	0.75
-37.5°	2.00	7.5°	0.35	52.5°	0.60
-35.0°	1.50	10.0°	0.50	55.0°	0.60
-32.5°	0.80	12.5°	1.80	57.5°	0.85
-30.0°	0.45	15.0°	2.40	60.0°	0.85
-27.5°	0.40	17.5°	2.85	62.5°	0.45
-25.0°	1.20	20.0°	2.90	65.0°	0.40
-22.5°	2.40	22.5°	2.35	-	-

Tab. 2: Position of intensity maxima as a function of diffraction order  $m$

$m$	$\alpha_m$	$\sin \alpha_m$
-3	-60.0°	-0.87
-2	-40.0°	-0.64
-1	-20.0°	-0.34
0	0.0°	0.00
1	20.0°	0.34
2	40.0°	0.64
3	60.0°	0.87

- Plot the angles of the diffraction maxima  $\alpha_m$  on a graph of  $\sin \alpha_m$  against diffraction order  $m$  (Fig. 6).

The measurements will lie along a straight line through the origin, whereby the gradient  $a$  corresponds to the quotient  $\lambda/d$  in accordance with equation (1). For a separation between slits of  $d = 10.5 \text{ cm}$  the wavelength  $\lambda$  and frequency  $f$  of the microwaves are given by the following:

$$a = \frac{\lambda}{d} \Leftrightarrow \lambda = a \cdot d = 0.302 \cdot 10.5 \text{ cm} = 3.17 \text{ cm} \Rightarrow$$

$$(4) \quad f = \frac{c}{\lambda} = \frac{3 \cdot 10^8 \frac{\text{m}}{\text{s}}}{3.17 \text{ cm}} = 9.5 \cdot \text{GHz}$$

The value agrees to within 1% with the nominal value of  $f = 9.4 \text{ GHz}$ .

### EVALUATION

#### Diffraction by a double slit

- You may need to subtract an offset (in this 0.30 V) from the measured voltages  $U$  (Table 1)

$$(2) \quad U' = U - U_{\text{off}} = U - 0.30 \text{ V},$$

For value at  $\alpha = 0^\circ$ ,

$$(3) \quad U'_{\text{max}} = U_{\text{max}} - U_{\text{off}} = 2.95 \text{ V} - 0.30 \text{ V} = 2.65 \text{ V},$$

Normalise the values including any offset and plot the resulting values  $U'/U'_{\text{max}}$  as a function of angle  $\alpha$  on a graph (Fig. 5).

- Identify the maxima with the respective diffraction order  $m$  and enter them along with the angles  $\alpha_m$  into Table 2.
- In each case determine the sine of the angle  $\alpha_m$  and enter them into Table 2.

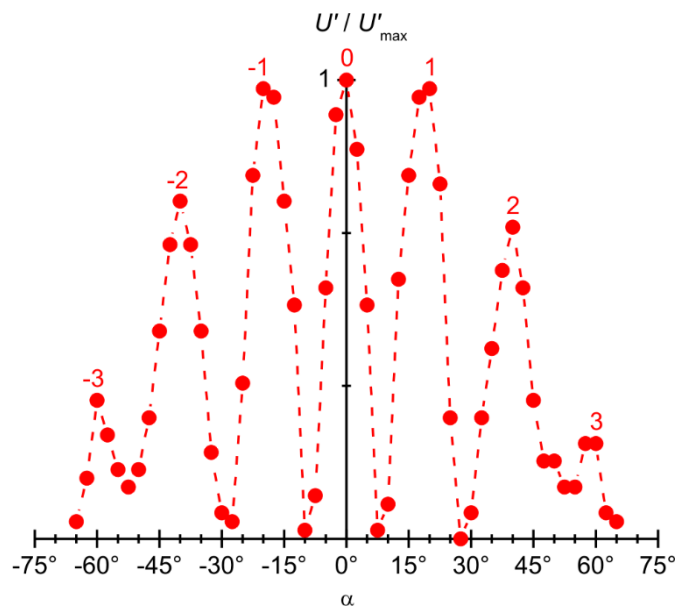

Fig. 5: Intensity distribution resulting from the diffraction of microwaves at a pair of slits. The dotted line is merely to help you see the pattern.

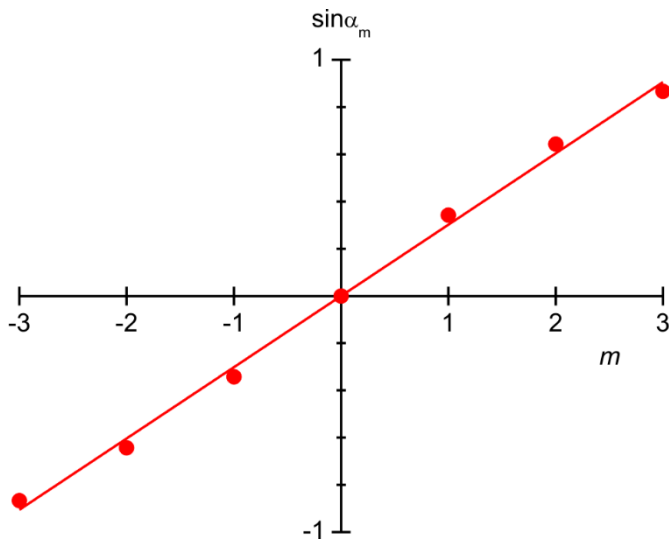

Fig. 6: Positions of the intensity maxima as a function of the diffraction order  $m$

### Polarisation

The analogue multimeter displays maximum voltage for parallel alignment of the transmitter and receiver (Fig. 4a). When the alignment is orthogonal (Fig. 4b), the meter displays zero. The microwaves transmitted are linearly polarised transverse waves.

When the polarisation grating is horizontally aligned between a transmitter and receiver, which are horizontal and parallel to one another (Fig. 4c), the analogue multimeter will display maximum voltage. When it is vertically aligned (Fig. 4d) the meter will display zero. The polarisation grating acts like a polarisation filter.

When the polarisation grating is diagonally aligned between a transmitter and receiver, which are parallel to one another (Fig. 4e) or orthogonal to one another (Fig. 4f), the analogue multimeter will display voltages somewhere between zero and the maximum voltage. The polarisation grating allows through those components of the electric vector in the incoming microwaves which oscillate parallel to its own alignment. Of these, the ones which are measured are those which oscillate parallel to the receiver.