



BPBIO750

User's Manual

使用手册

BPBIO750 User Manual for Measurement Guide and Setup

Thank you for purchasing the BPBIO750. This user's manual describes all the features of the BPBIO750. Please read before use and keep it in a safe place. By following the manual instructions, you will be able to use the BPBIO750 more safely and effectively.

BPBIO750测量姿势引导及安装使用手册

感谢您购买BPBIO750。本使用手册对BPBIO750的所有功能进行了详细易懂的说明。使用前请认真阅读本使用手册，并将其妥善保管在常见的位置。熟知操作方法及注意事项，以便于您能安全、正确且高效地使用BPBIO750。



Please note the important information below before reading this manual.

Warning

Failure to observe these precautions can result in personal injury or damage to the equipment.

Caution

Failure to comply with safety precautions can damage the equipment.

Note

Reading the notes can help you get the most out of your device.

Avertissement

Le non-respect de ses précautions peut causer des blessures ou des dommages à l'appareil.

Attention

Le non-respect de ses précautions peut causer des dommages à l'appareil.

Remarque

Se référer aux notes peut aider à améliorer l'utilisation de l'appareil.

在阅读本手册之前，请注意下列重要信息。

警告

若不遵循安全警告和指示规定可导致重伤或死亡。

注意

若不遵循安全注意事项可能导致受伤或设备损坏。

参考

帮助用户理解的说明。



Contents

I. BPBIO750 Installation		I. BPBIO750电子血压计的安装	
A. Product Components	5	A. 产品组成	37
B. Operating Environment	6	B. 操作环境	38
C. Installation Instructions	6	C. 安装指南	38
D. Loading and Reloading Printer Paper	10	D. 打印纸安装和替换	41
E. Replacing Cuff Cover	11	E. 袖带更换	42
F. Setup	13	F. 设置菜单	44
G. Connecting to InBody	17	G. 连接InBody人体成分分析仪	48
H. Precautions for Maintenance	18	H. 维护	49
II. Blood Pressure Test		II. 血压测量	
A. Preparatory Steps	19	A. 测量前注意事项	50
B. Test Instructions	19	B. 测量方法	50
C. Test Posture	22	C. 测量姿势	53
III. Transportation and Storage		III. 运输和储存	
A. Transportation Precautions	23	A. 运输注意事项	54
B. Repacking Instructions	24	B. 重新包装指南	55
C. Transportation and Storage Environment	24	C. 运输及储存环境	55
IV. FAQ		IV. 常见问题解答	
A. Error Code	25	A. 错误代码	56
B. Regarding the Equipment	25	B. 关于设备	56
C. Regarding the Test	27	C. 关于血压测量	58
V. Others		V. 其他	
A. Exterior and Functions	29	A. 外观及功能	60
B. Safety Information	30	B. 安全信息	61
C. Product Classification	31	C. 产品分类	61
D. Specifications	32	D. EMC声明	62
E. EMC Information (Declaration)	33	E. 规格	66

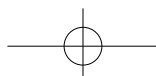
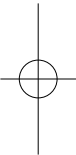
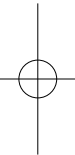

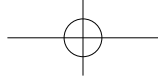

BPBIO750

User's Manual

English



I. BPBIO750 Installation

A. Product Components

The BPBIO750 consists of the following components. Make sure all of the components are present.

* Please check each component for damage prior to installation.

Standard Components

- ① The BPBIO750
- ② Power cable 110V or 220V (AC 250V 10A 1.8m (70.9 in.)) 1 EA
- ③ Printer paper 2 EA
- ④ User's manual
- ⑤ Cuff covers 2 EA; 1 installed

Optional Components

- ⑥ Desk for the BPBIO750
- ⑦ Chair for the BPBIO750

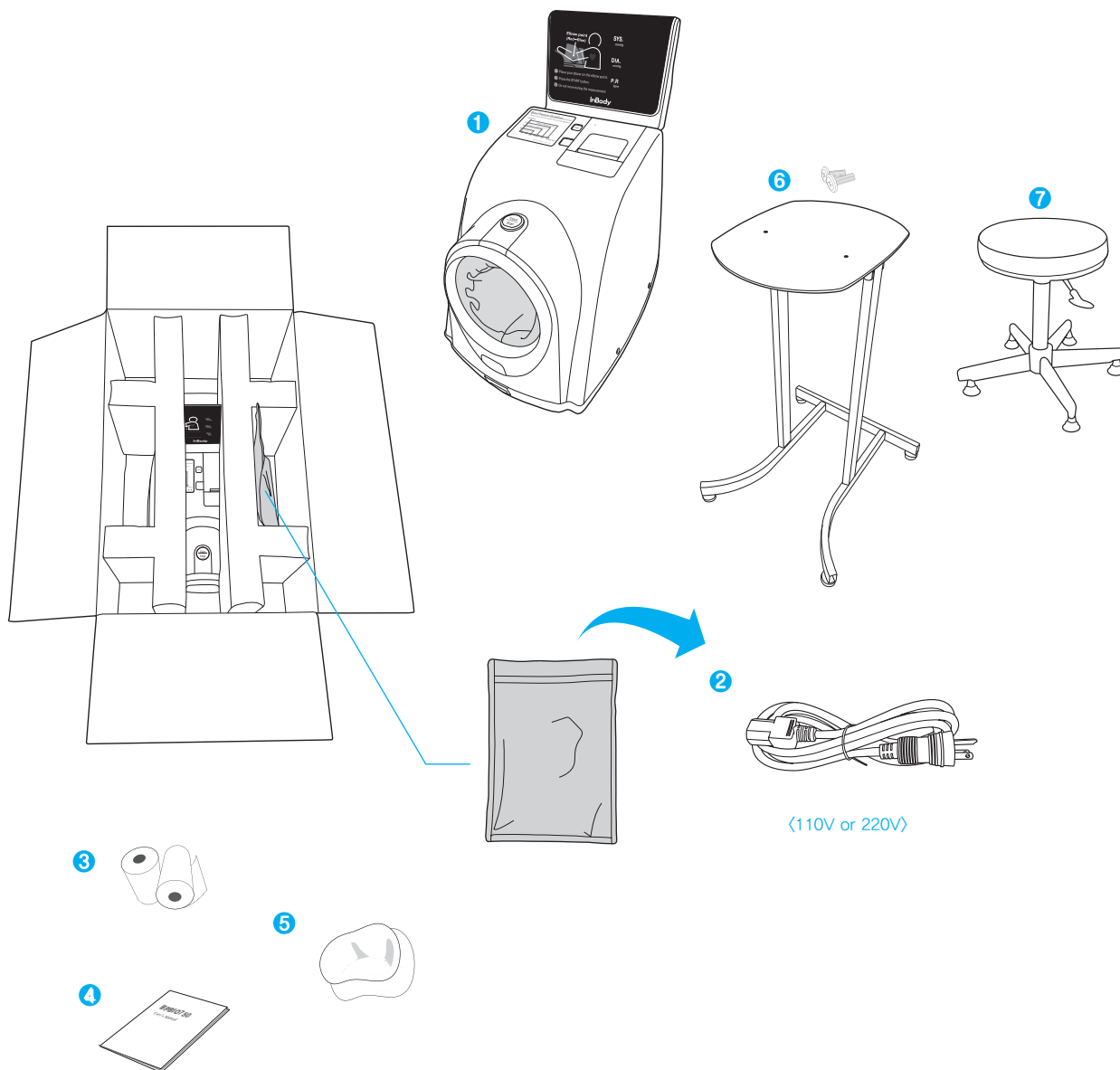



B. Operating Environment

Please make sure the environment is appropriate for the BPBIO750 installation. This equipment is designed for indoor use. If installing the equipment outdoors, the following requirements must be fulfilled.

Temperature range	10 to 40°C (50 to 104°F)
Relative humidity	30 to 75% RH
Atmospheric pressure range	70 to 106 kPa

C. Installation Instructions

1. Open the BPBIO750 box and remove the packing pads. Remove the protective vinyl on the BPBIO750 and take it out of the box. Remove the packing material.

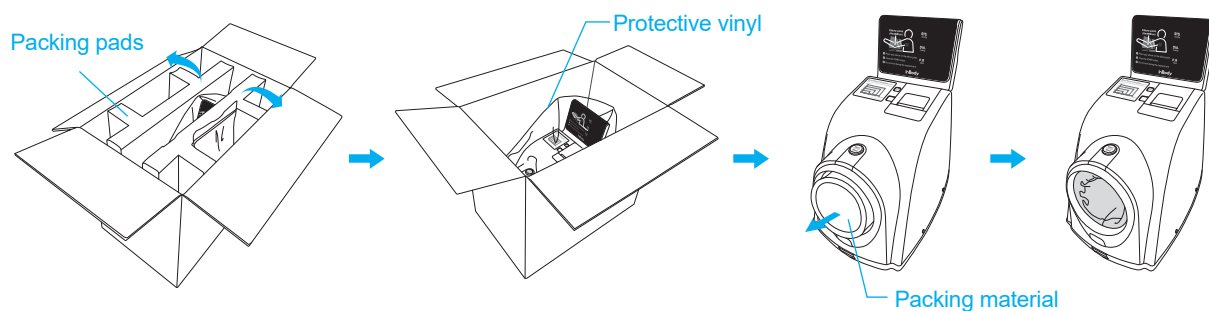

! Caution

- Do not carry the equipment by the cuff.
- Keep packing material to store the BPBIO750. Dispose of trash according to local laws and regulations.
- Refer to the figure below when transporting the BPBIO750.

! Attention

- *Ne transportez pas l'appareil en le tenant par le brassard.*
- *Conservez l'emballage original de l'appareil BPBIO750 pour le réemballer ultérieurement. Disposez des déchets selon la réglementation locale en vigueur.*
- *Référez-vous à l'illustration ci-dessous pour transporter l'appareil BPBIO750.*

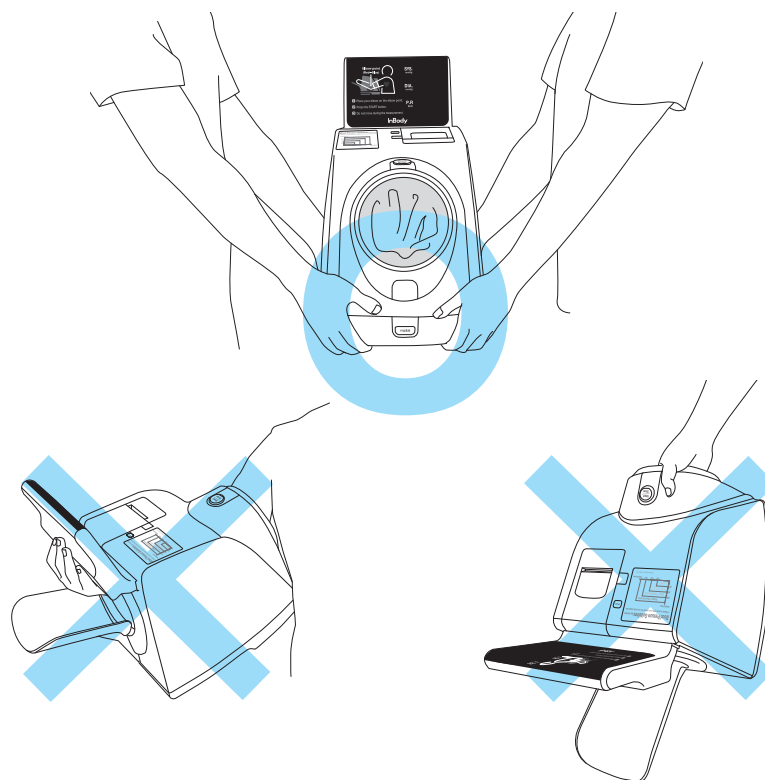

- Place the equipment on a solid table that can withstand the weight of the BPBIO750 (approx. 7.1kg (15.65lb)).
If using the optional BPBIO750 desk, align the desk fixing grooves on the bottom of the BPBIO750 with the grooves on the desk and secure them with the two fixing screws.

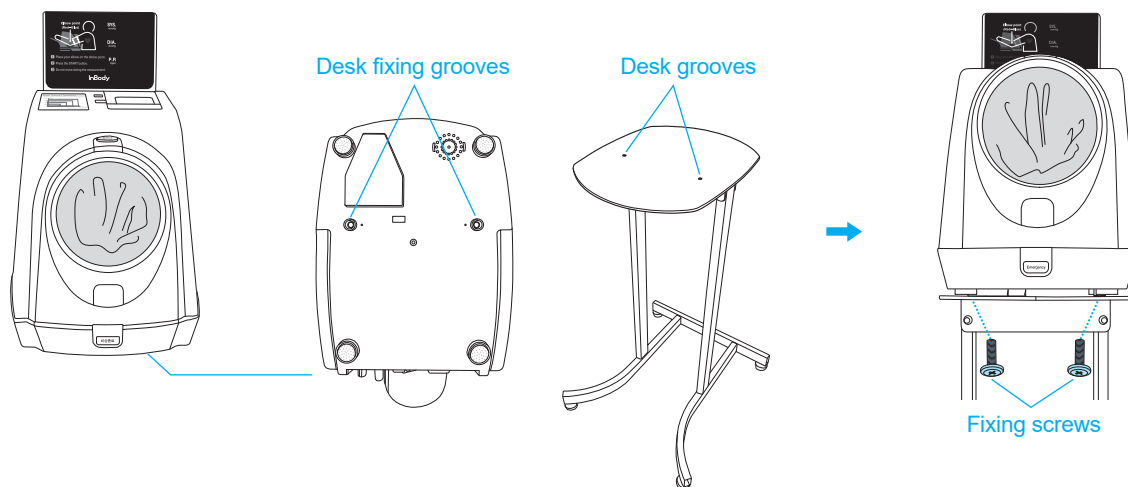

⚠ Caution

- Install the BPBIO750 on a flat, vibration-free surface.
If the device is installed on a surface that is not flat, it may topple during testing or the results may be inaccurate.

⚠ Attention

- Installer le BPBIO750 sur un sol plat et sans vibration.*
Si l'équipement est installé sur un sol qui n'est pas plat, il peut glisser pendant un test ou les résultats peuvent être inexacts.

- Connect the provided power cable.
* Plug the power cable into a grounded 3-prong outlet.

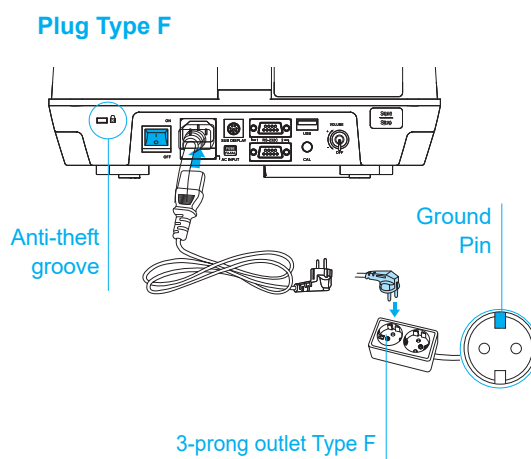
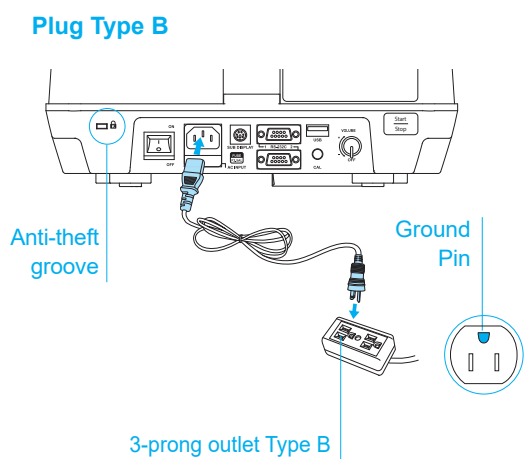



Warning

- Do not install the equipment where the power cable is difficult to disconnect.
- To avoid electric shock, do not plug or disconnect the power cable with wet hands.
- Always use an outlet designed for the correct power supply (AC100-240 V). An incorrect power supply may cause fire or equipment malfunction.
- If using a multiple tab, ensure it has a sufficient power capacity or use an extension cable.
- Do not disassemble the equipment arbitrarily. This may cause electric shock or injury, product malfunction, and/or inaccurate results. Unauthorized disassembly will void the manufacturer's warranty.
- Do not let the BPBIO750 touch other electronic devices when turned on. This may cause electric shock.

Caution

- Plugging the device into an ungrounded outlet may cause malfunction or electric shock and/or inaccurate results.

Avertissement

- *N'installez pas l'appareil dans un lieu difficile d'accès.*
- *Ne branchez pas et ne débranchez pas le câble d'alimentation si vos mains sont mouillées; ce geste comporte des risques d'électrocution.*
- *Utilisez toujours une prise reliée à un circuit électrique approprié (CA 100-240V); dans le cas contraire, un incendie ou un mauvais fonctionnement pourrait se produire.*
- *Lorsque vous utilisez une prise multiple, assurez-vous qu'elle fournit suffisamment de puissance, ou utilisez une rallonge électrique.*
- *Ne démontez pas l'appareil de façon arbitraire; ceci comporte des risques d'électrocution et de blessure, un mauvais fonctionnement de l'appareil, et des résultats inexacts. Le cas échéant, la garantie du fabricant serait annulée.*
- *Ne mettez pas l'appareil BPBIO750 en contact avec d'autres appareils électroniques lorsqu'il est en marche, ceci comporte des risques d'électrocution.*

Attention

- *Branchez l'appareil à une prise de courant n'ayant pas été mise à terre pourrait causer un mauvais fonctionnement et/ou des résultats inexacts.*

4. Use the anti-theft groove to prevent theft.

* Theft protection cable is sold separately.

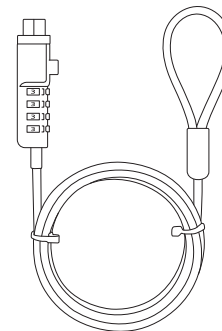

5. Turn the BPBIO750 on by pressing the power switch located on the back of the device.

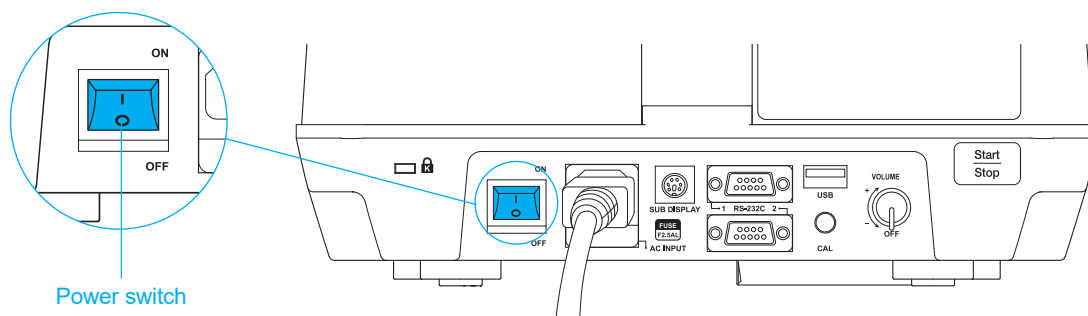

Power switch

6. When powered on, the BPBIO750 will automatically calibrate and display the following screen.

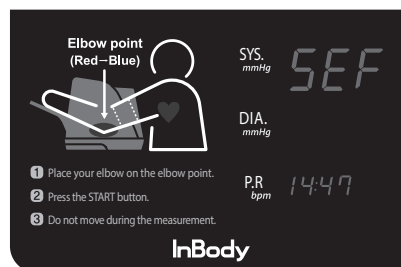
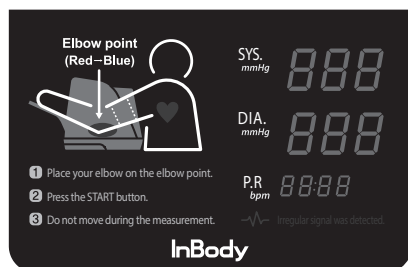

⚠ Caution

- Do not operate or touch the device while it is calibrating. It may cause errors to future tests.

⚠ Attention

- *Ne manipulez pas l'appareil BPBIO750 et ne le faites pas fonctionner pendant qu'il effectue un test automatique (env. 10 s); des erreurs et des résultats inexacts pourraient en résulter.*

7. Adjust the volume by turning the volume knob on the rear of the BPBIO750.

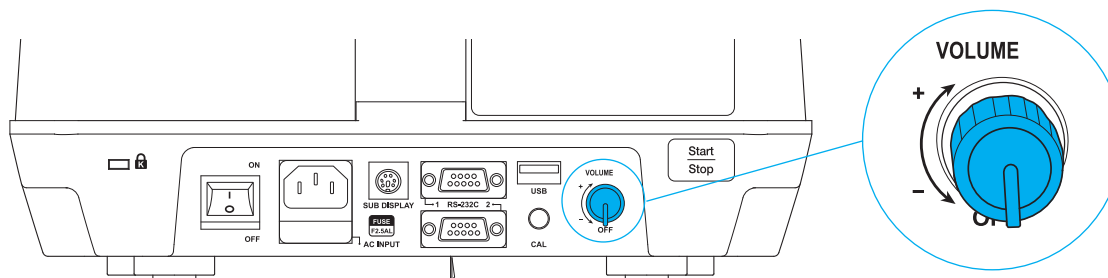



D. Loading and Reloading Printer Paper

1. Press the button shown below to open the cover while the BPBIO750 is turned on.

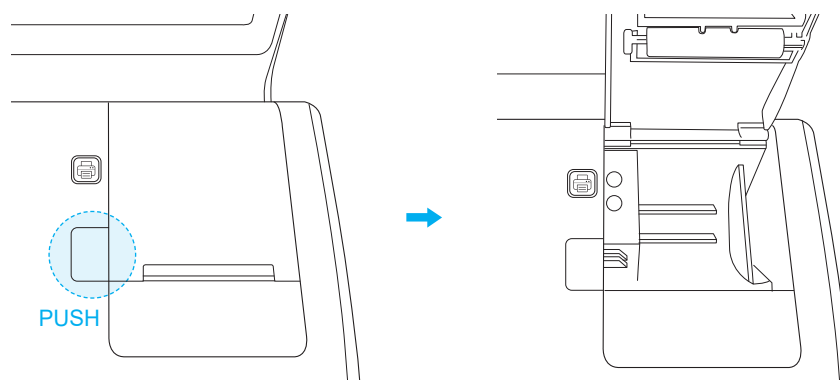

2. Insert the printer paper in the direction as shown below.

After inserting the printer paper, let a certain amount of paper come out of the cover, then close it to complete the installation.

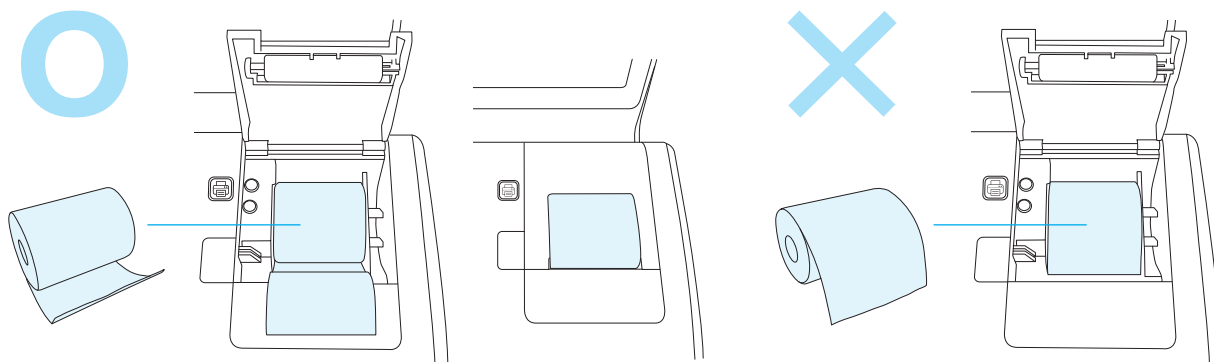

Caution

- The printer will not work if the paper is inserted in the wrong direction.
- Remove all trash from previous printer paper rolls when replacing with the new printer paper.

Note

- Two rolls of printer paper are provided with the BPBIO750.
- If an additional printer paper roll is needed, it may be purchased separately.

Attention

- *L'imprimante ne fonctionnera pas si le papier n'est pas inséré adéquatement.*
- *Assurez-vous de bien retirer les résidus du papier précédent lorsque vous rechargez le papier d'impression.*

Remarque

- *Deux rouleaux de papiers sont fournis avec le BPBIO750.*
- *Si du papier supplémentaire est nécessaire, l'utilisateur peut l'acheter séparément comme un article consommable.*



E. Replacing Cuff Cover

The cuff cover of the BPBIO750 should be replaced periodically for sanitary purposes. Follow the guide below to replace the cuff cover.

1. Remove the front cover of the BPBIO750 by pushing downward, and loosen the screw with a screwdriver. Remove the ring on the front of the BPBIO750 by pulling it forward.

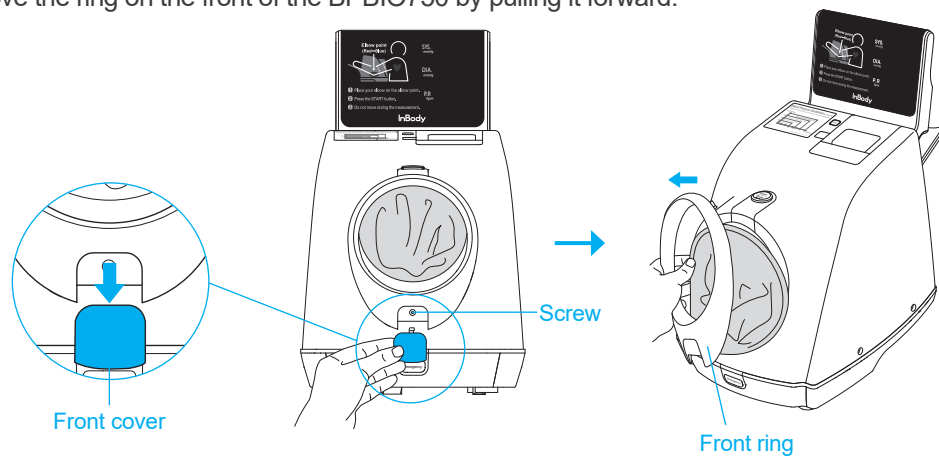

2. Push in the seam of the cuff cover as shown below to separate the cuff cover.

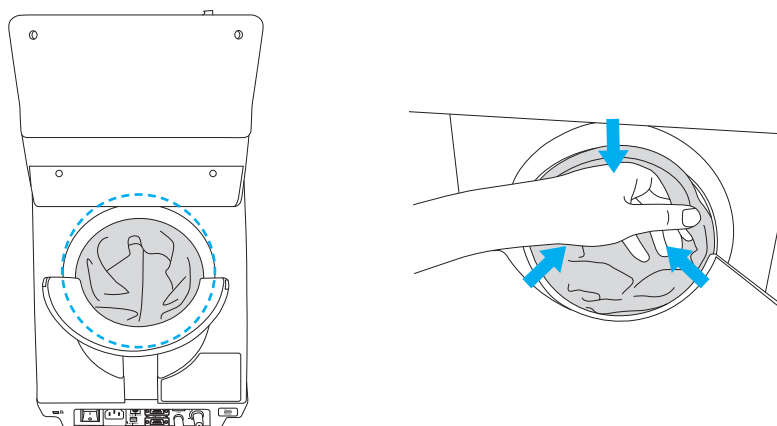

3. Pull the cuff cover as shown below to remove it from the device.

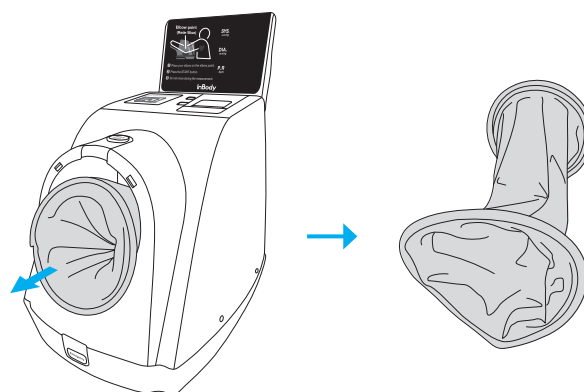



4. Place the seam of the new cuff cover down as shown below, and align it with front and rear ring.

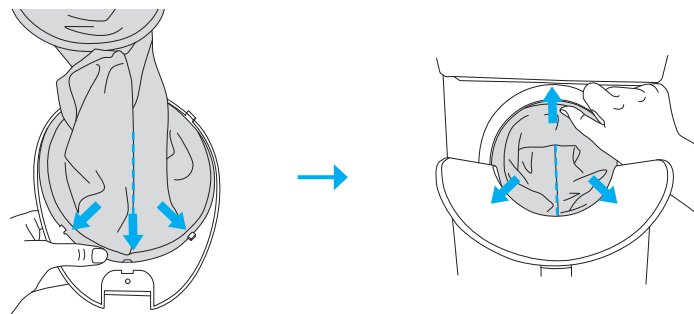

Caution

- The blood pressure reading may be inaccurate if the seam does not face down.

Attention

- Les résultats de la pression artérielle pourraient être faussés si la ligne de couture n'est pas placée vers le bas.

5. Reattach the front and rear rings to the BPBIO750 and secure them with the screws. Close the front cover of the BPBIO750.

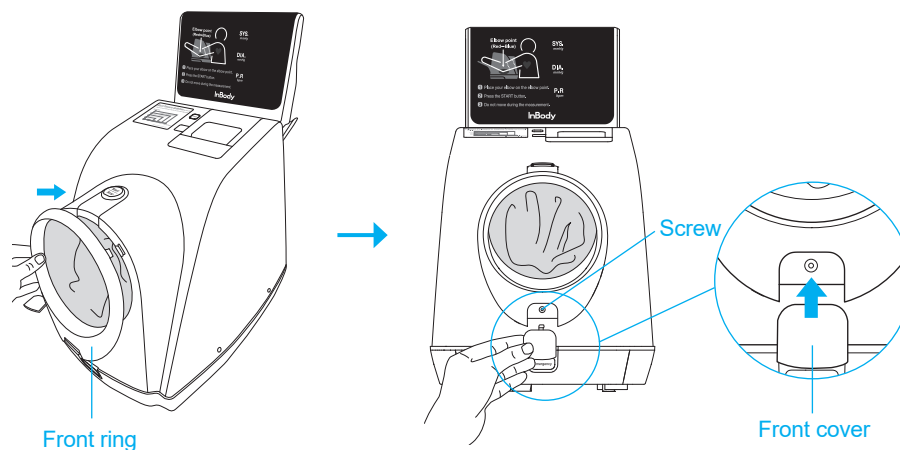

Note

- Two cuff covers are included with the BPBIO750. (One is already installed in the equipment.)
- You may purchase additional cuff covers separately.

Remarque

- Deux housses de brassard sont fournies avec l'appareil BPBIO750, l'une d'elles est préalablement installée sur l'équipement.
- Au besoin, l'utilisateur peut faire l'achat de nouvelles housses de brassard auprès de son fournisseur.

F. Setup

Setup consists of time settings, sound settings, Result Sheet printing, pressure unit setting, and communication settings.

1. Configuring Setup

- 1) When the 'Start/Stop' and 'Print' buttons are pressed and held simultaneously for 2 seconds while on the home screen, 'F01' (Time setting) will blink.

The current setting status will be shown in the Diastolic (HOU) column and Pulse (Hour value) column.

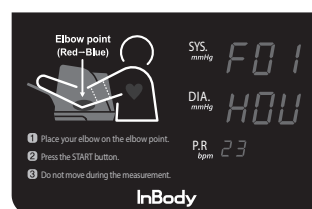
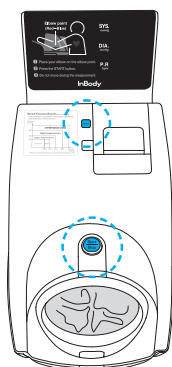

- 2) When the Systolic column is blinking, you can go to the desired setting item.

Press UP / DOWN buttons to move to the other setting items.

* UP/DOWN buttons are located beneath the printer cover of the device.

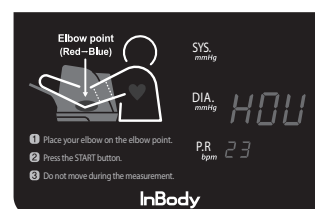
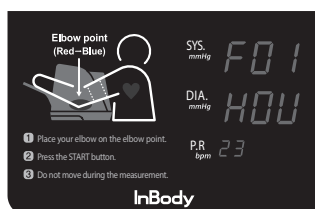
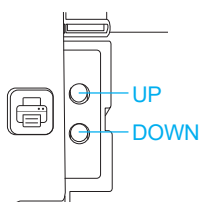

- 3) To adjust the setting value, press the 'Start/Stop' button.

The set value can be changed with the UP / DOWN buttons, and the set value of the corresponding item is displayed in the Pulse column.

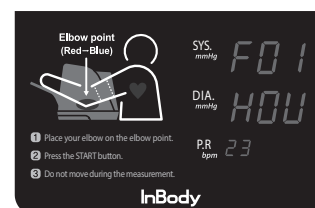
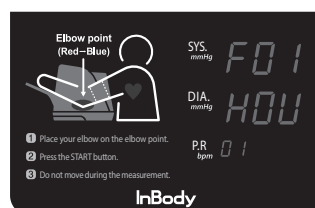
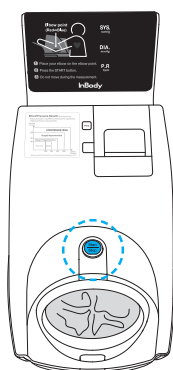



- 4) Press the 'Start/Stop' button to save the setting value. Then, you can go back to the desired setting item.

- 5) Once you are finished adjusting all settings, press and hold the Print button for 2 seconds to return to the home screen.

2. Setup Example

The following is an example showing how to change the automatic Result Sheet printing option to manual printing option.

- 1) While on the home screen, press and hold the  and  buttons simultaneously time for more than 2 seconds. The current setting is shown on the 'F01' screen, the first screen of Setup.

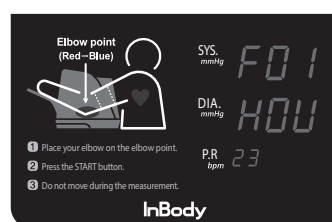
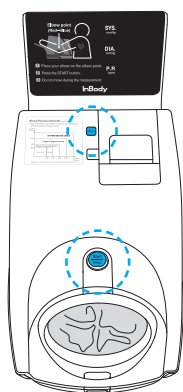

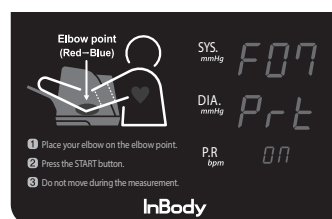
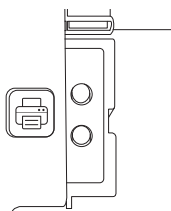

- 2) Press the 'UP/DOWN' buttons to go to 'F07 P-r-t' screen.
In the Pulse column, the current setting value is displayed as '00'.

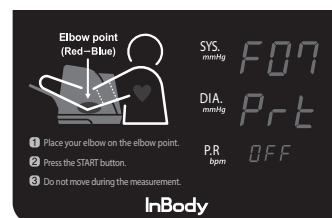
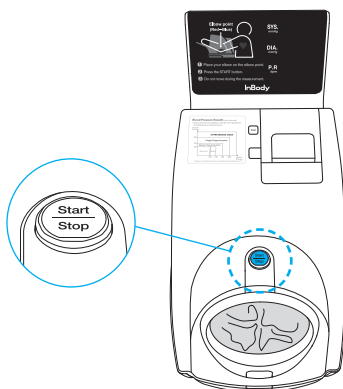

- 3) Press the  button to enter the corresponding item, and then use the UP / DOWN buttons to change the current setting value from '00' to 'OFF'.



- 4) Press the  button to save the setting value, and the display will return to the Setup screen.
- 5) Check the setting value of the Pulse column to confirm your desired setting, then press and hold the  button for 2 seconds to return back to the home screen.

3. Detailed description of Setup

When configuring Setup, the following messages will be displayed in the Systolic, Diastolic, and Pulse screen.

Function	Screen			Description	
	Systolic	Diastolic	Pulse		
Hour setting	F01	HOU	14	Setting hour (0-23)	
Minute setting	F02	MIN	15	Setting minute (0-59)	
Year setting	F03	YER	20 17	Setting year (2000-2035)	
Month setting	F04	MEH	10	Setting month (1-12)	
Day setting	F05	DAY	22	Setting day (1-31)	
Sound	F06	Snd	1.U01	Read test instructions and measurement results	
			2.U02	Read test instructions only	
			3.U03	Read measurement results only	
			4.bEP	Beep guide	
Printing options	F07	Prt	ON	Automatic printing of Result Sheet	
			OFF	Manual printing of Result Sheet	
Screen timeout duration	F08	LCD	5	Display the test result value for 5 seconds	
			10	Display the test result value for 10 seconds	
			20	Display the test result value for 20 seconds	
			30	Display the test result value for 30 seconds	
			60	Display the test result value for 60 seconds	
Date output format	F09	dAt	1.Ynd	YY / MM / DD	
			2.ndY	MM / DD / YY	
			3.dnY	DD / MM / YY	
Pressure unit	F10	Un1	1.H9	mmHg	
Communication	F11	232	1.Inb	InBody	
			2.PC	PC	
Result Sheet item	Type of Result Sheet	F12	Fot	1.5nL	3-line automatic output (vertical) * F13-F18 function not available
				2.b19	3-line automatic output (horizontal)
	Additional result values	F13	6oP	ON	Output of Mean arterial pressure / Pulse pressure / Pressure rate product
				OFF	Not used
	Blood pressure graph	F14	9rP	ON	Print blood pressure graph
				OFF	Not used
	Test posture check	F15	Arn	ON	Guide output about the elbow placement
				OFF	Not used



Result Sheet item	Blood Pressure Knowledge	<i>F 16</i>	<i>not</i>	<i>ON</i>	Output of additional blood pressure information on the Result Sheet
				<i>OFF</i>	Not used
	Pulse Evelope	<i>F 17</i>	<i>PUL</i>	<i>ON</i>	Pulse Evelope output on the Result Sheet
				<i>OFF</i>	Not used
Logo	<i>F 18</i>	<i>Lo9</i>	<i>ON</i>	Customized logo on the Result Sheet	
			<i>OFF</i>	Not used	
Setting up the Elbow Sensor		<i>F 19</i>	<i>SEn</i>	<i>ON</i>	Elbow sensor is functional
				<i>OFF</i>	Elbow sensor is disabled
Result Sheet item	QR Code	<i>F20</i>	<i>qr</i>	<i>ON</i>	QR code output
				<i>OFF</i>	Not used
Measurement mode setting	3 consecutive measurements	<i>F21</i>	<i>AV9</i>	<i>ON</i>	3 consecutive measurements mode
				<i>OFF</i>	One-time measurement mode

* "QR Code" is registered trademark of DENSO WAVE INCORPORATED.



G. Connecting to InBody

You can connect the BPBIO750 to InBody body composition analyzers to transfer over blood pressure measurements.

- * Only compatible with other InBody products.
- * Blood pressure values can be printed on the InBody Result Sheet.
- * Serial cable is sold separately.

1. Turn off the BPBIO750.

2. Connect the serial cable to the RS232C (9-pin serial) connection terminal located on the back of the BPBIO750. Connect the other end of the serial cable to the serial connection terminal on the InBody device.

- * Refer to the InBody user's manual to find the location of the serial connection terminal.

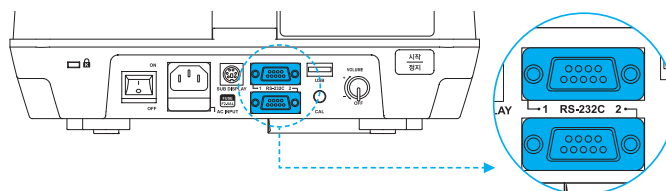

Example: InBody770

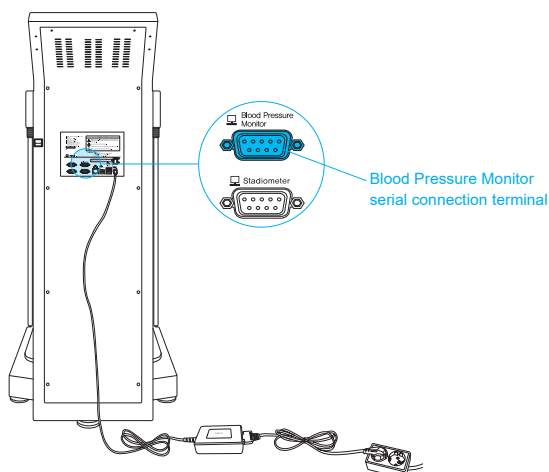

3. Turn on the BPBIO750.

4. Devices will connect automatically.

Note

- Refer to the InBody user's manual to print the blood pressure values on the InBody Result Sheet.

Remarque

- Consultez le manuel du produit d'InBody pour la méthode d'impression des valeurs de la pression artérielle sur la fiche des résultats d'InBody.



H. Precautions for Maintenance

Caution

- Never move the equipment while the power is on.
- Do not let foreign objects like dust and liquid enter the device, as they can cause damage to electrical components.
- Clean the exterior of the equipment gently with a lint-free cloth once a week.
Do not scratch the LED screen while cleaning the equipment.
- Replace the cuff cover when it becomes dirty or worn out.
- Packing material and other waste should be disposed of according to the relevant laws and regulations.

Check the following before turning the equipment on.

- Make sure the equipment was not damaged from impact.
- Make sure the equipment is not contaminated.
- Make sure the equipment is not wet.
- Make sure the power cord is completely plugged in.
- Make sure the power cord is not damaged.
- Make sure the power cord is not a tripping hazard.

The BPBIO750 calibrates automatically when it is turned on, but it may be necessary for a specialist to inspect the device once every two years to maintain its performance and safety. If an error message appears during calibration, please contact product support.

Attention

- *Ne déplacez pas l'appareil lorsqu'il fonctionne.*
- *Ne laissez aucun corps étranger, tel de la poussière ou du liquide s'insérer dans l'appareil; ces derniers pourraient endommager les composantes électriques.*
- *Nettoyez l'extérieur de l'appareil avec un chiffon doux et non pelucheux une fois par semaine, veillez à ne pas gratter l'écran D.E.L. lors du nettoyage de l'appareil.*
- *Remplacez la housse du brassard lorsque celle-ci devient sale ou trop usée.*
- *Vous devez disposer des emballages et autres déchets conformément à la réglementation locale en vigueur.*

Avant d'allumer l'appareil, assurez-vous que :

- *l'appareil n'ait pas subi de dommage à la suite d'un impact*
- *l'appareil n'est pas contaminé*
- *l'appareil n'est pas mouillé*
- *le cordon d'alimentation est bien inséré dans la prise murale.*
- *le cordon d'alimentation n'est pas endommagé*
- *le cordon d'alimentation ne constitue pas un risque de chute.*

Si un message d'erreur (code d'erreur) apparaît pendant l'auto-test, veuillez contacter le revendeur ou le centre de service à la clientèle.

II. Blood Pressure Test

A. Preparatory Steps

! Caution

- Examinee should rest at least 5 to 10 minutes before the test.
- Do not roll up the examinee's sleeve; instead, remove thick clothing
- Examinee should sit up straight in the chair.
- Insert the examinee's arm until the elbow is positioned in the elbow groove.
- Adjust the height of the chair so that the inserted upper arm and heart are horizontal.
- Test in a relaxed state.
- Examinee should not talk or move during the test.

! Attention

- *Il est recommandé que l'utilisateur se repose de 5 à 10 minutes avant le test.*
- *Il n'est pas nécessaire de relever la manche de l'utilisateur, mais ce dernier devrait enlever les vêtements plus épais.*
- *L'utilisateur doit s'asseoir bien droit sur la chaise.*
- *Insérez le bras de l'utilisateur dans le brassard jusqu'à ce que son coude atteigne le point prévu à cet effet.*
- *Ajustez la hauteur du siège afin que l'avant-bras de l'utilisateur, une fois inséré dans l'appareil, soit parallèle à son cœur.*
- *Assurez-vous que l'utilisateur soit détendu pendant le test.*
- *Assurez-vous que l'utilisateur ne parle pas et ne bouge pas pendant le test.*

B. Test Instructions

1. Adjust the height of the chair so that the inserted upper arm and heart are horizontal.

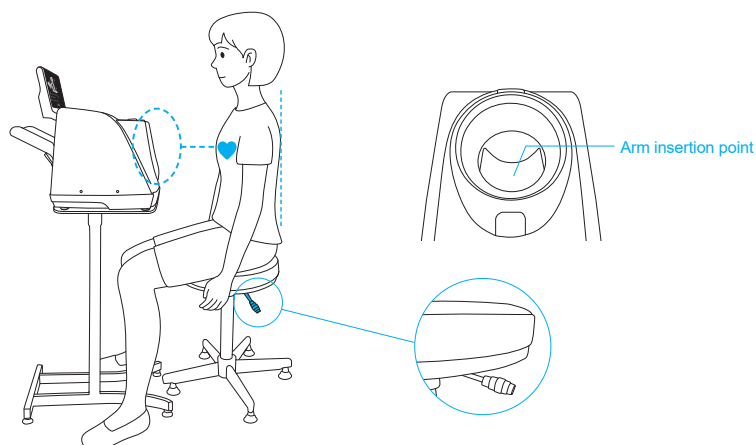

2. Rest for at least 5 minutes prior to taking the test.

* If examinee tests in an agitated state, the results may be inaccurate and read higher than normal.



3. Insert the arm until the elbow is positioned in the elbow groove, as shown below.

* When the elbow is placed in the right position, the blue LED light will light up on the display.

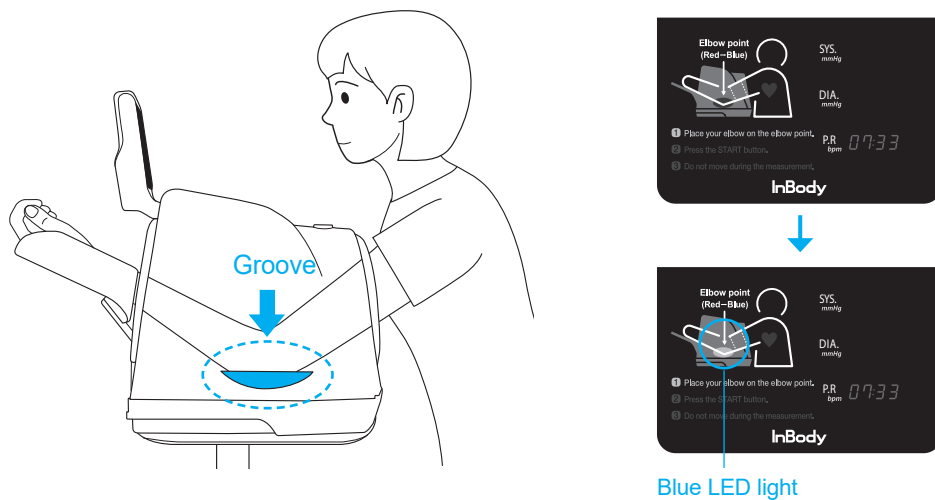

4. Press the Start/Stop button to start the test.

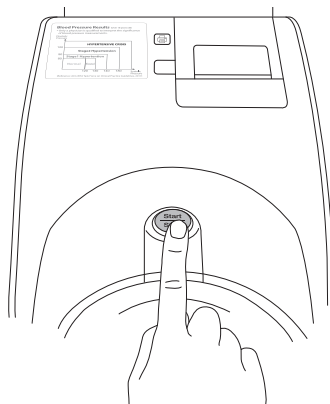

5. The cuff automatically pressurizes, and blood pressure is measured.

* Do not talk or move during the test.

* Relax while sitting up straight.

Caution

• If an emergency occurs during the test, press the **Start/Stop** or **Emergency stop** buttons on the bottom (toward the front) of the BPBIO750 - the cuff will quickly release.

Attention

• Si une urgence survient pendant le test, appuyez sur le bouton Arrêt/Marche ou Arrêt d'urgence, en bas sur le devant du BPBIO750. la pression du brassard se relâchera automatiquement.

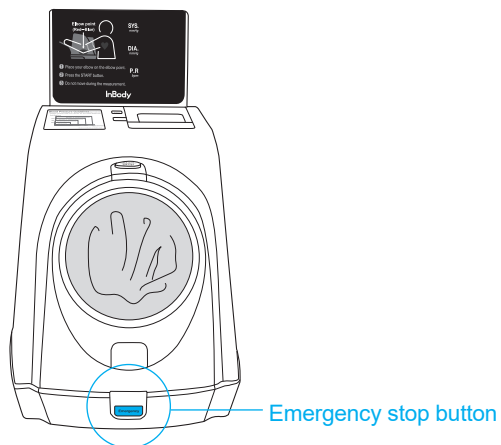



6. The cuff automatically releases once the test has completed. Wait for the cuff to fully loosen before pulling out your arm.

7. Check the results on the screen.

* The voice guidance will activate and the Result Sheet will print according to your settings.

Elbow point (Red-Blue)

SYS. mmHg 113 — Systolic blood pressure

DIA. mmHg 68 — Diastolic blood pressure

P.R. bpm 88 — Pulse rate

1 Place your elbow on the elbow point.
2 Press the START button.
3 Do not move during the measurement.

InBody

Irregular signal was detected.

Elbow position LED

- Blue: Elbow is placed in the right position
- Red: Elbow is not placed in the right position.

- When the test is not completed due to movement or other factors
- When irregular pulse is detected

* Users may refer to the 'Blood Pressure Results' at the bottom left side of the device to check their blood pressure status.

* Please consult with your physician for accurate diagnosis.

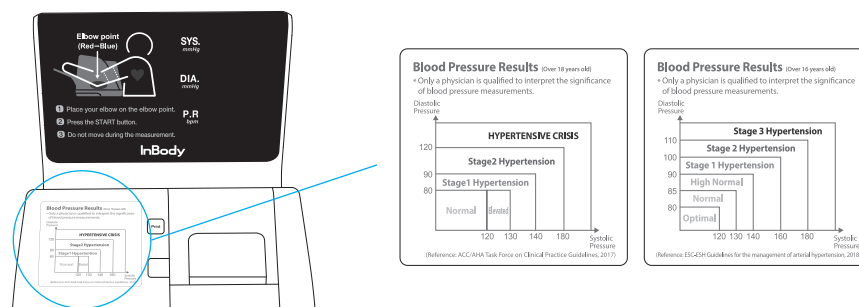

8. Others

The Start/Stop button on the rear of the BPBIO750 also allows you to initiate the test, which can be useful for the administrator to conduct the test from the back of the device.

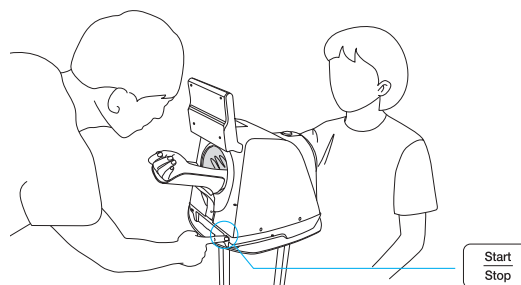

Note

- If the examinee wants to test their blood pressure again, please instruct them to rest for at least 5 minutes.
- Blood pressure can vary depending on the testing conditions. Please consult your physician for accurate diagnosis.

Remarque

- Si l'utilisateur veut reprendre le test de tension artérielle, bien vouloir se reposer suffisamment au moins 5 minutes avant de le faire.
- La tension artérielle peut varier selon la situation. Bien vouloir consulter votre médecin pour un diagnostic exact.



C. Test Posture

For the most accurate results, get into the proper posture for testing.

* The BPBIO750 allows examinees to measure with either arm.

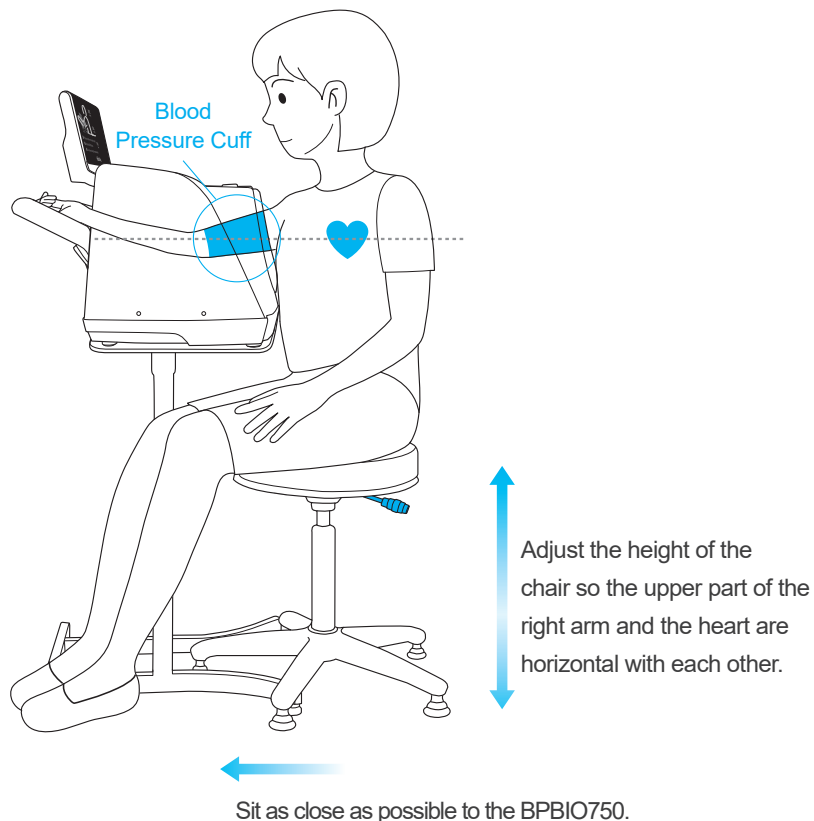

* Be sure to place the elbow in the elbow groove before starting the test.

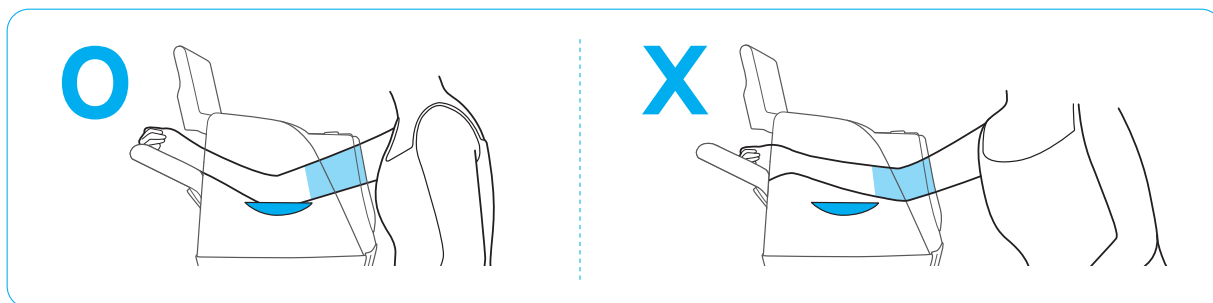

* Remove thick clothing. Do not roll up sleeves.

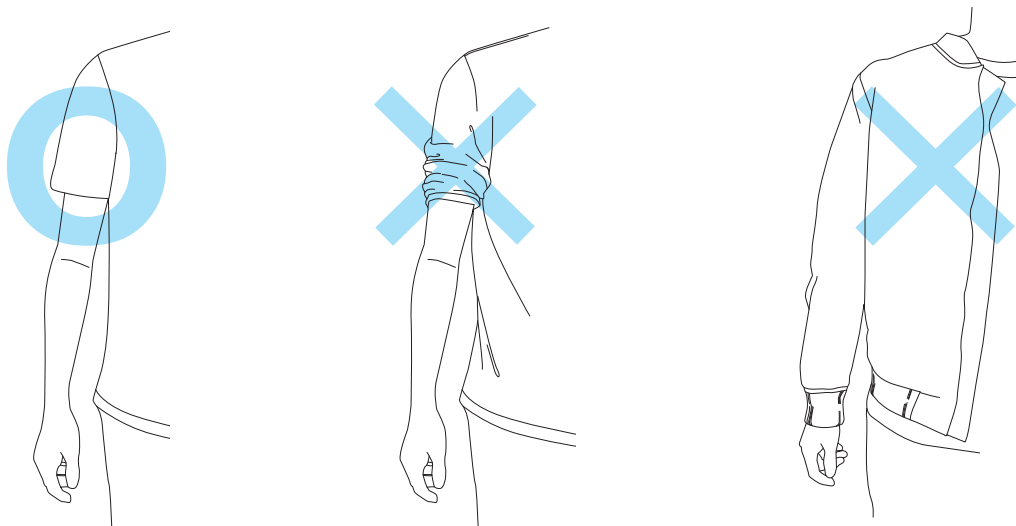

III. Transportation and Storage

A. Cautions during Transportation

To transport the BPBIO750 securely, two people should keep the equipment parallel to the ground.



 **Caution**

- When transporting the equipment alone, keep the device horizontal.

 **Attention**

- *Lorsque vous transportez l'équipement seul de façon inévitable, soulevez-le en le maintenant horizontal comme suit.*

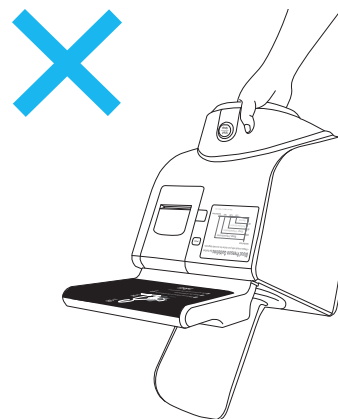
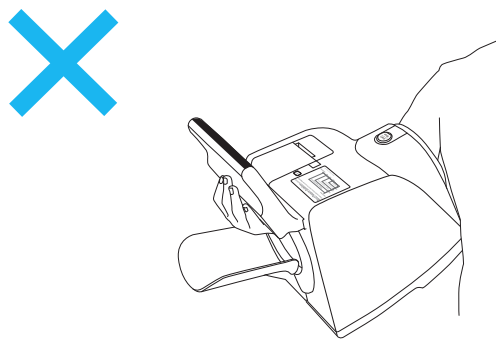
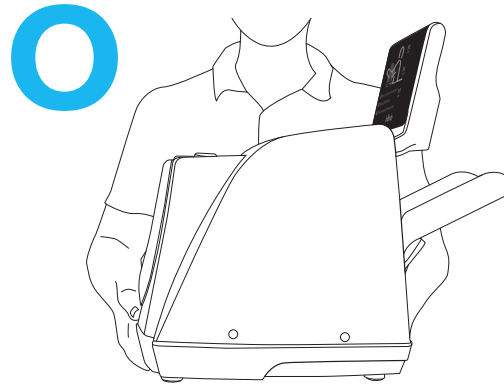
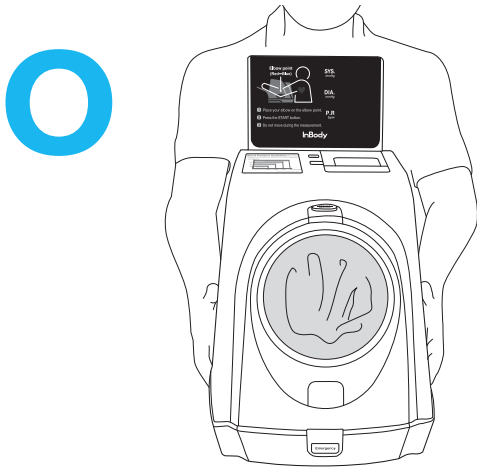



B. Repacking Instructions

1. Turn off the BPBIO750.
2. Remove all connected cables and put the packing material into the BPBIO750. Wrap package in protective vinyl and insert the packing pads into the box.

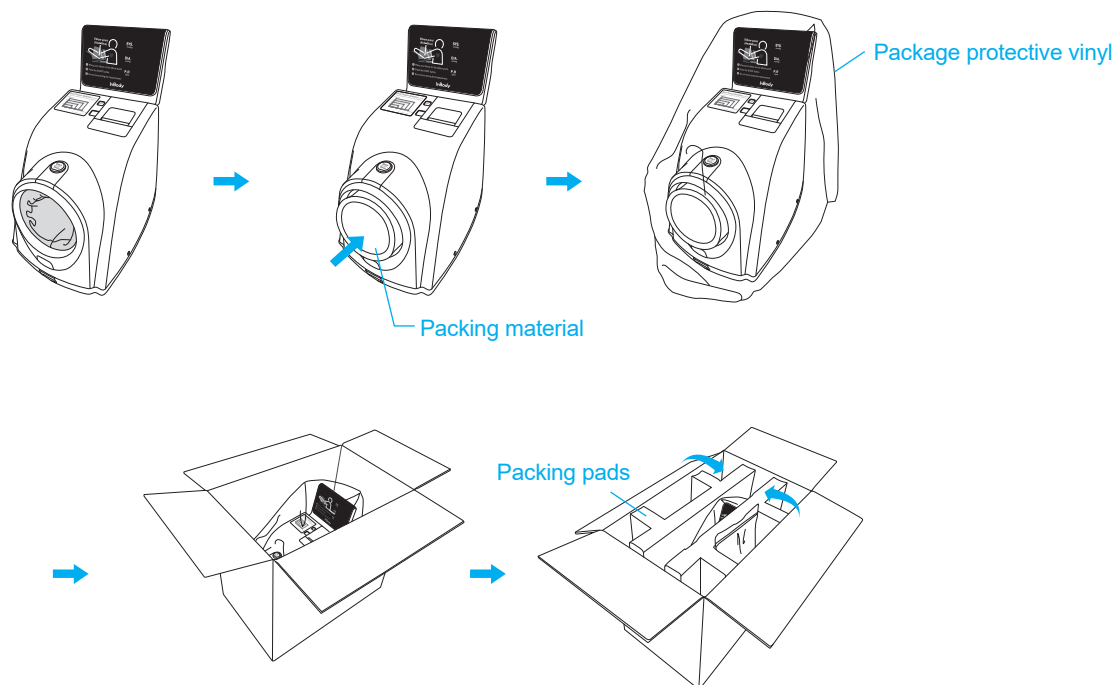

! Caution

- When repacking the equipment, use the protective packing material included with the device.

! Attention

- *Veillez à utiliser le matériel d'emballage d'origine si vous devez réemballer l'appareil.*

C. Transportation and Storage Environment

The BPBIO750 should be transported or stored under the following conditions.

Temperatures range	-10 to 70°C (14 to 158°F)
Relative humidity	10 to 80% RH (No Condensation)
Atmospheric pressure range	50 to 106 kPa

IV. FAQ

If a problem persists, please contact Product Support.

A. Error Code

The error messages will display on the screen if they occur during the test.

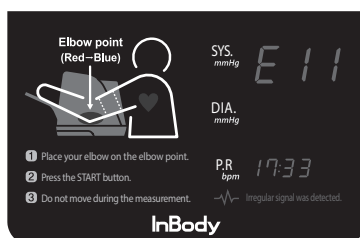

Please provide the error code to Product Support.

B. Regarding the Equipment

If your technical issues cannot be resolved with the information below, please contact Product Support.

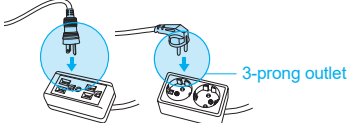
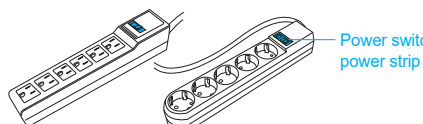
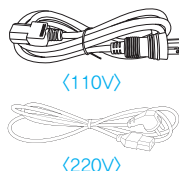
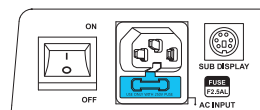
Issue	Potential Solution
<ul style="list-style-type: none"> The device is not turning on. 	<ul style="list-style-type: none"> Plug the power cable into a properly grounded (3-prong) outlet. 
	<ul style="list-style-type: none"> When using a power strip, make sure the switch is turned on. 
	<ul style="list-style-type: none"> Make sure you are using the power cable (AC 250V 10A) provided by InBody. 
	<ul style="list-style-type: none"> Issue may occur when the fuse is blown. Replace the fuse by following the instructions below: <ol style="list-style-type: none"> The fuse socket is located on the back of the device beneath the power plug.  Pull the fuse out by using a flathead screwdriver. Replace the fuse with the provided spare fuse. Additional fuses can be purchased if necessary.



Issue	Potential Solution
-------	--------------------

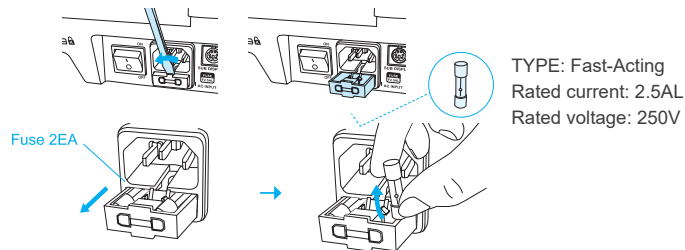

Warning

- Be sure to turn off the power when replacing the fuse.
- The correct fuse must be used. (250V, 2.5AL)

Avertissement

- Éteignez complètement l'appareil lorsque vous devez remplacer le fusible.
- Veillez à utiliser un fusible de calibre approprié (250V, 2.5 A)

- | | |
|---|---|
| <ul style="list-style-type: none"> • Voice guidance does not work. | <ul style="list-style-type: none"> • This may occur when the volume knob on the rear of the BPBIO 750 is turned off. Adjust the volume knob to your desired level. |
|---|---|

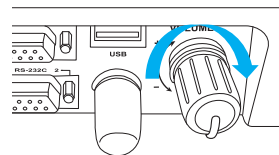

- This may occur when the Sound is set to Beep sound output. 'F05'. When the Sound is set to '4.BEP', only the beep sound occurs. If you want the Voice sound output, change the Sound to '1.UOI'.
- * Refer to the 'Setup' on page 12.

- | | |
|---|--|
| <ul style="list-style-type: none"> • The Result Sheet is not printing. | <ul style="list-style-type: none"> • This may occur when the Result Sheet setting has not been set to print the Result Sheet. When Automatic Printing Option 'F07' is set to 'OFF', the Result Sheet will be printed manually. If you want automatic printing, change the setting to 'ON'. * Refer to the 'Setup' on page 12. • This may occur when the printer is out of paper. Open the printer cover and check if the printer paper needs to be replaced. • This may occur when the printer paper is installed incorrectly. Open the printer cover and check the positioning of the printer paper. • This may occur when the printer cover is not closed completely. Make sure that the printer cover is closed properly. * Refer to 'Loading and Reloading Printer Paper' on page 9. |
|---|--|

Caution

- The company is not liable for any issues that occur when parties outside of InBody employees repair and inspect the equipment.

Note

- Error messages and collateral like Result Sheets containing errors can be used to assist with A/S request; please record or keep these items.

Attention



- InBody Co, Ltd se décharge de toute responsabilité en cas de problème si la maintenance et l'inspection de votre appareil ne sont pas effectuées par un technicien accrédité ou un employé de la société.

Remarque

- Puisque les messages d'erreurs et/ou les fiches de résultats erronés peuvent être utilisés pour le service après-vente, veuillez en prendre note dans un registre et/ou garder les copies en filière.

C. Regarding the Test

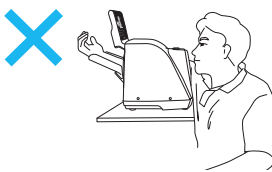
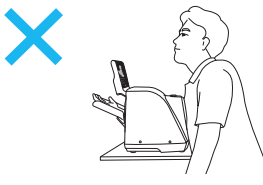
If your technical issues cannot be resolved with the information below, please contact Product Support.

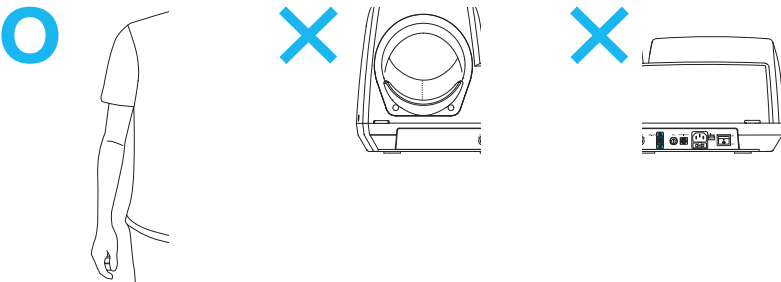
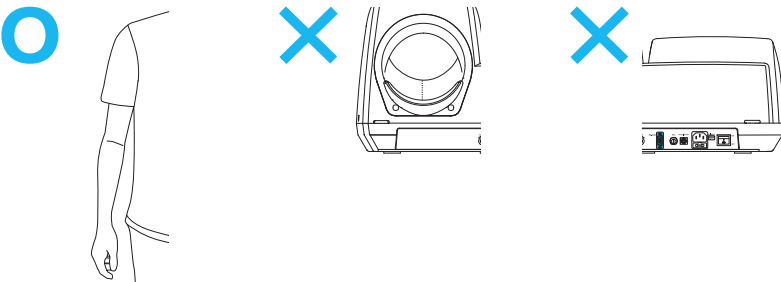
Issue	Potential Solution
<ul style="list-style-type: none"> The test results are incorrect. 	<ul style="list-style-type: none"> The arm and heart may not be aligned during the test. Adjust the height of the chair to align the arm and heart.
	<p>Correct testing posture. The height of the arm and the heart is aligned.</p>
	<p>Incorrect testing posture. The arm is higher than the heart. Blood pressure value will be measured lower.</p>
	<p>Incorrect testing posture. The arm is lower than the heart. Blood pressure value will be measured higher.</p>
<ul style="list-style-type: none"> Inserting the arm too far or not far enough may produce incorrect results. Place elbow in elbow groove for accurate results. 	
<ul style="list-style-type: none"> Thick clothing or rolled up sleeves may produce incorrect results. 	<ul style="list-style-type: none"> * The blood pressure value will be measured higher. Remove thick clothing. Do not roll up sleeves.
	
<ul style="list-style-type: none"> The examinee may have tested without resting beforehand. Take the test after resting at least 5 minutes. * The first reading may be high even after taking a sufficient rest. Do not talk or move during the test. 	

* Blood pressure may vary throughout the day. InBody recommends testing at different times of the day.



Issue	Potential Solution
<ul style="list-style-type: none"> When should blood pressure be measured? 	<ul style="list-style-type: none"> Blood pressure may vary throughout the day, as shown below.  <p>Therefore, the best time to test is when examinees can measure regularly on a daily basis. It is recommended to test at the same time each day under the same conditions.</p>
<ul style="list-style-type: none"> How frequently can tests be done? 	<ul style="list-style-type: none"> The automatic monitor applies pressure to the arm to measure blood pressure. Consecutive testing may put a strain on blood vessel. Rest for about 5 minutes between tests.
<ul style="list-style-type: none"> Is there any case that I should not test? 	<ul style="list-style-type: none"> If you had blood drawn or had an injection given in either arm, it is recommended to wait at least 1 hour before testing, or measure with another arm.
<ul style="list-style-type: none"> Can results vary depending on the testing environment and temperature? 	<ul style="list-style-type: none"> The BPBIO750 can operate at 10-40°C (50-104°F). However, if the examinee feels that the temperature is too low or high, the blood vessels expand or contract, which will affect the blood pressure results. It is recommended to test in a stable condition in an environment where the temperature is at a comfortable level. The examinee will not be able to perform a natural and stable test if they are testing in a loud or disruptive environment. It is recommended to test in an environment free from noise and disturbances.
<ul style="list-style-type: none"> What are some factors that can change blood pressure? 	<ul style="list-style-type: none"> The blood pressure reading may change: <ul style="list-style-type: none"> - Within 1 hour after meals - After having alcohol or caffeine - After smoking - After taking a bath - After exercise - After using the restroom - When testing in an unfamiliar location
<ul style="list-style-type: none"> The blood pressure values are different when taken at home compared to the hospital. 	<ul style="list-style-type: none"> Blood pressure can change depending on the environment. Test in the same environment for consistent results. Psychologically, people tend to feel more relaxed at home than the hospital. Blood pressure tends to be higher when measured at the hospital than at home.

V. Others















* The BPBIO750 was manufactured according to the quality control procedure of InBody Co., Ltd. InBody complies with ISO9001 and ISO13485, which are international quality management systems.

* This equipment satisfies the common standard for electrical and mechanical safety of medical devices and the common standard for the safety of medical devices.

A. Exterior and Functions

Below is a list of BPBIO750 components and its function.

* Please check each component of the system for damage prior to installation.

- 1  : A display screen showing results, time, and test instructions
- 2  : A blood pressure guideline
- 3  : A button to print Result Sheets
- 4  : A button to start or stop a test
- 5  : Emergency stop button
- 6  : Printer paper cover
- 7 8  : UP/DOWN buttons to adjust settings
- 9  : A switch to turn the equipment on/off
- 10  : Input for external power source (110-120/200-240V, 50/60Hz), Fuse (F2.5AL, 250V)
- 11  : A terminal to communicate with the multi-display device
- 12  : RS232C (9-pin serial) connection terminal
- 13  : USB Port
- 14  : A port to connect a mercury monitor to adjust the pressure value
- 15  : Volume control knob
- 16  : Rear Start/Stop button

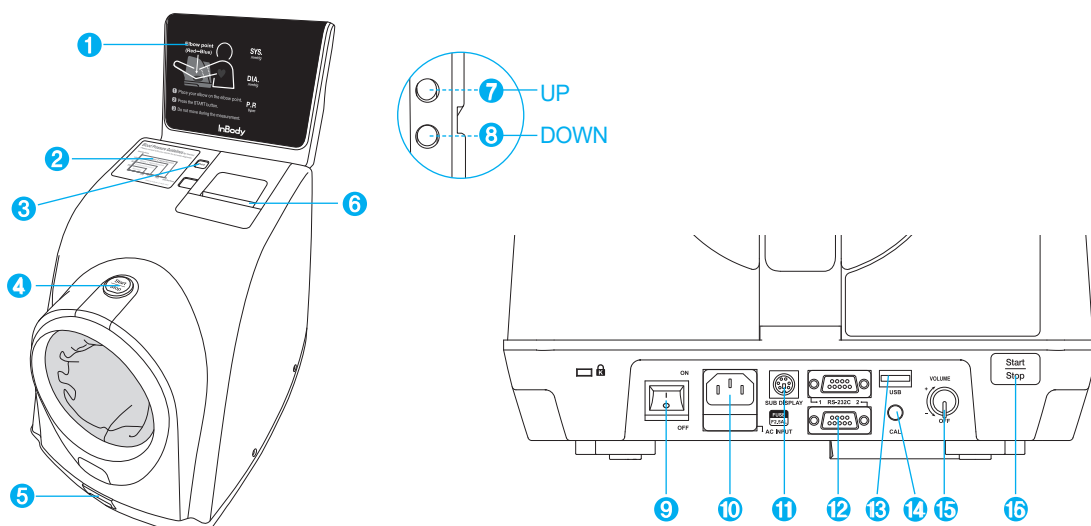



B. Safety Information

Warning

- If this equipment has been altered, it must be inspected to ensure that it can be used safely.
- Results can only be interpreted by experienced healthcare professionals. It cannot be used for diagnosis, medication, or other treatments performed at the consumer's discretion without a doctor's prescription.

Caution

- Excessively high or low temperatures, humidity, and pressure may affect the operation of the equipment and cause malfunction. Use the blood pressure monitor within the range specified in the product specifications.
- Do not touch the external device connections such as RS232C (9-pin serial) connection terminal on the back of the equipment.
- Packing material and other waste should be disposed of according to the relevant laws and regulations.







Avertissement

- *Si l'équipement a été modifié, il doit être inspecté pour vous assurer qu'il peut être utilisé de façon sécuritaire.*
- *Seul un les professionnels de la santé peuvent interpréter le sens des résultats. Ils ne peuvent être utilisés aux fins d'un diagnostic, ordonnance, ou autres traitements reçus à la discrétion du consommateur, sans ordonnance médicale.*







Attention

- *Les températures extrêmes (très élevées ou très basses), l'humidité et la pression atmosphérique peuvent affecter le fonctionnement de l'appareil et provoquer un mauvais fonctionnement. Utiliser le tensiomètre conformément aux spécification du produit.*
- *Ne touchez pas aux dispositifs de branchement externes de l'appareil tels le câble de branchement de série RS232C au dos de l'appareil.*
- *Vous devez disposer des emballages et autres déchets conformément à la réglementation locale en vigueur.*

Safety Symbols

	Danger: high voltage
	Warning / Caution
	Note
	BF-type equipment
	Power on
	Power off

Etc. Symbols

 1639	European Conformity		Serial number
	Manufacturer		Alternating current
	Authorized representative in the EUROPEAN COMMUNITY		Operating instructions
	NRTL mark (MET)		

* MET symbols apply to products sold in the United States and Canada.

C. Product Classification

Oscillometric multi-functional electronic blood pressure monitor

- Type of protection against electric shock: Class 1 device
- Level of protection against electric shock: BF-type
- Class of protection against electromagnetic radiation intensity: Class A
- Level of protection against flooding: General Equipment (No special protection against external water infiltration)

D. Product Specifications

Test Instructions	Oscillometric
Test range	Pressure: 0 to 300 mmHg Pulse: 30 to 240 bpm
Degree of precision	Pressure: ± 2 mmHg Pulse: Within $\pm 1.5\%$
Test result	Systolic blood pressure, diastolic blood pressure, pulse rate, pulse pressure, mean arterial pressure, rate pressure product
Test Time	Approx. 30 seconds on average (20-50 seconds depending on the pulse and blood pressure value)
Pressurization Time	Approx. 10 seconds
Minimum scale unit	1mmHg
Screen Type	7-Segment LED
Results Sheet outputs	Systolic and Diastolic blood pressure, Mean arterial pressure, Pulse pressure, pulse, Rate pressure product, Pulse envelope, Blood pressure graph, Check posture, and Blood pressure knowledge
Storage function	Can store the total results for up to 1 million tests
Energy saving	Automatically enters the energy saving mode after 2 minutes of the idle time
Dual safety mechanism	The air will be released when the Start/Stop button is pressed. The air will be released automatically when the air pressure exceeds 300 mmHg. The air will be released when the Emergency Stop button is pressed. (The dual safety mechanism enables the cuff to release the air regardless of the central controller when the Emergency Stop button is pressed.)
Voice guidance	Guides user through blood pressure measurement and results
Printer	High-speed thermal printer with a built-in automatic cutter (width: 2.5 inch/6.35 cm)
Rated voltage and Power consumption	AC 100-120 / 200-240V, 50/60Hz, 36VA
Dimensions	Approx. 299 (W) \times 547 (D) \times 485 (H) mm Approx. 11.8 (W) \times 21.5 (D) \times 19.1 (H) in
Weight	Approx. 7.1 kg (15.65 lb)
Operating environment	Temperature 10 ~ 40°C (50 ~ 104°F) , Humidity 30 ~ 75% RH, Atmospheric pressure 70 ~ 106 kPa
Storage environment	Temperature -10 ~ 70°C (14 ~ 158°F), Humidity 10 ~ 80% RH, Atmospheric pressure 50 ~ 106 kPa (No Condensation)

* Specifications are subject to change without notice for purposes of product improvement.

* This product is a 'medical equipment'. Please read the guide and cautions before using this blood pressure monitor.

E. EMC Declaration

Test Name	IEC 60601-1-2 4th Edition	Ref. Standard	Ports to Test	AC Mains Voltage	Test Level Required	Notes
Mains terminal disturbance voltage	4th	CISPR 11:2015/AMD2:2019	AC Mains	100V, 50Hz 100V, 60Hz 120V, 60Hz 220V, 60Hz 230V, 50Hz	Group 1, Class B	
Radiated disturbance	4th	CISPR 11:2015/AMD2:2019	Enclosure	100V, 50Hz 100V, 60Hz 120V, 60Hz 220V, 60Hz 230V, 50Hz Battery	Group 1, Class B	
Harmonic Current Emissions	4th	IEC 61000-3-2:2018	AC Mains	230V~50Hz	Class A	
Voltage Fluctuations and Flicker	4th	IEC 61000-3-3:2013/AMD1:2017	AC Mains	230V~50Hz	Pst = 1 Plt = 0.65 Dmax = 4% DC = 3.3%	
Electrostatic Discharges (ESD)	4th	IEC 61000-4-2:2008	Enclosure	100V, 50Hz 100V, 60Hz 120V, 60Hz 220V, 60Hz 230V, 50Hz Battery	±8 kv contact ±2 kv, ±4 kv ±8 kv, ±15 kv Air	1 pulse/ 1sec contact 8 kv air 15kV
Radiated RF electromagnetic Fields	4th	IEC 61000-4-2:2008	Enclosure	100V, 50Hz 100V, 60Hz 120V, 60Hz 220V, 60Hz 230V, 50Hz Battery	10 V/m 80 MHz-2.7 GHz 80% AM at 1kHz RF Wireless Comm. (Refer to test report clause 1.15)	Dwell Time is 3 sec
Electric Fast Transients and bursts	4th	IEC 61000-4-4:2012	AC Mains	100V, 50Hz 100V, 60Hz 120V, 60Hz 220V, 60Hz 230V, 50Hz	±2 kv, AC, 100 hk PRR	5 pulses at 0°, 90°, 180°, 270°
Surges	4th	IEC 61000-4-5:2014/AMD1:2017	AC Mains	100V, 50Hz 100V, 60Hz 120V, 60Hz 220V, 60Hz 230V, 50Hz	±0.5 kv, ±1 kv L to N (CM) ±0.5 kv, ±1 kv ±2 kv L & N to PE (CM)	5 pulses at 0°, 90°, 180°, 270°
Conducted Disturbances, induced by RF fields	4th	IEC 61000-4-6:2013	AC Mains & all I/O	100V, 50Hz 100V, 60Hz 120V, 60Hz 220V, 60Hz 230V, 50Hz Battery	3 Vrms 150 Hk to 80 Mk 80% AM at 1Hk, 2Hz 6 Vrms in ISM Bands, amateur radio bands between 0.15 Mk and 80Mk	Dwell time is 3 sec



Power-frequency Magnetic Field	4th	IEC 61000-4-8:2009	Enclosure	100V, 50Hz 100V, 60Hz 120V, 60Hz 220V, 60Hz 230V, 50Hz Battery	30 A/m 50 Hz & 60 Hz	
Voltage Dips, Interruptions, and variations	4th	IEC61000-4-11:2004/ AMD1:2017	AC Mains	100V, 50Hz 100V, 60Hz 120V, 60Hz 220V, 60Hz 240V, 50Hz 240V, 60Hz	0% UT for 0.5 cycle	AT 0°, 45°, 90°, 135°, 180°, 225°, 270°, 315°
					0% UT for 1 cycle	AT 0°, 180°
					50Hz : 70% UT for 25 cycles 60Hz : 70% UT for 30 cycles	AT 0°, 180°
					50Hz : 70% UT for 250 cycles 60Hz : 70% UT for 300 cycles	AT 0°, 180°



Electromagnetic immunity

The [Model name] is intended for use in an electromagnetic environment in which radiated RF disturbances are controlled. Portable RF communications equipment should be used no closer than 30 cm (12 inches) to any part of the [Model name]. Otherwise, degradation of the performance of this equipment could result.

Immunity test	Band a)	Service a)	Modulation b)	IEC60601 test level	Compliance level
Proximity fields from RF wireless Communications IEC61000-4-3	380 - 390 MHz	TETRA 400	Pulse modulation b) 18Hz	27 V/m	27 V/m
	430 – 470 MHz	GMRS 460 FRS 460	FM c) ±5 kHz deviation 1 kHz sine	28 V/m	28V/m
	704 – 787 MHz	LTE Band13, 17	Pulse modulation b) 217 Hz	9 V/m	9 V/m
	800 – 960 MHz	GSM800:900 TETRA 800 iDEN 820 CDMA 850 LTE Band 5	Pulse modulation b) 18 Hz	28 V/m	28V/m
	1700 – 1990 MHz	GSM 1800 CDMA 1900 GSM 1900 DECT LTE Band 1,2,4,25 UMTS	Pulse modulation b) 217 Hz	28 V/m	28V/m
	2400 – 2570 MHz	Bluetooth WLAN 802.11b/g/n RFID 2450 LTE Band 7	Pulse modulation b) 217 Hz	28V/m	28V/m
	5100 – 5800 MHz	WLAN 802.11a/n	Pulse modulation b) 217 Hz	9 V/m	9 V/m

NOTE : If necessary to achieve the IMMUNITY TEST LEVEL, the distance between the transmitting antenna and the ME EQUIPMENT or ME SYSTEM may be reduced to 1m. The 1m test distance is permitted by IEC 61000-4-3.

- a) For some services, only the uplink frequencies are included.
- b) The carrier shall be modulated using a 50% duty cycle square wave signal.
- c) As an alternative to FM modulation, 50% pulse modulation at 18 Hz may be used because while it does not represent actual modulation, it would be worst case.



BPBIO750

使用手冊

中國語



I. BPBIO750电子血压计的安裝

A. 产品组成

BPBIO750产品组成如下。请确认包装内的各个组件是否齐全。

*安装前请确认各个部分是否完好无损。

基本配置

- 1 BPBIO750 主机 1台
- 2 电源线 (AC 250V 10A 1.8m) 1根
- 3 热敏打印纸 2卷
- 4 使用手册 1本
- 5 袖带 2个 (1个已安装在设备上)

*袖带适用臂围：17~42cm

*袖带使用期限同产品有效期

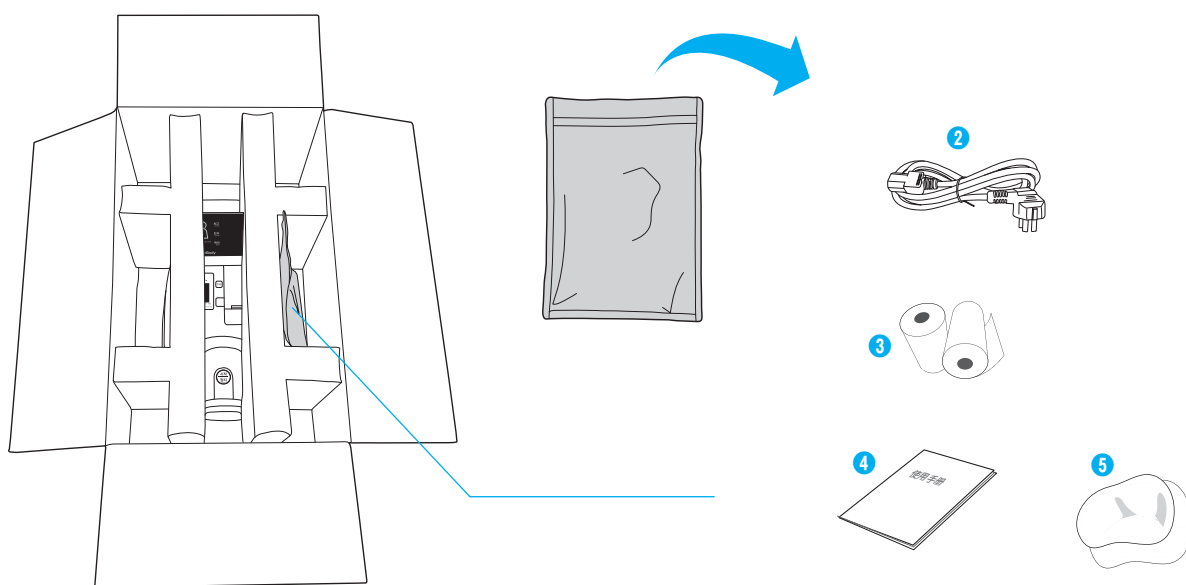
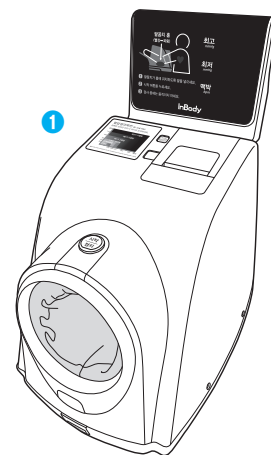

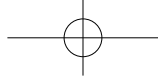

B. 操作环境

安装BPBIO750之前请确认安装操作环境。该设备用于室内使用，若需在室外使用，请确保环境符合以下要求。

温度	10 ~ 40°C
湿度	30 ~ 75% RH
气压	70 ~ 106kPa

C. 安装指南

1. 打开BPBIO750之后，取出包装缓冲垫。从包装保护塑料袋取出设备后，取出袖带位置的固定垫。

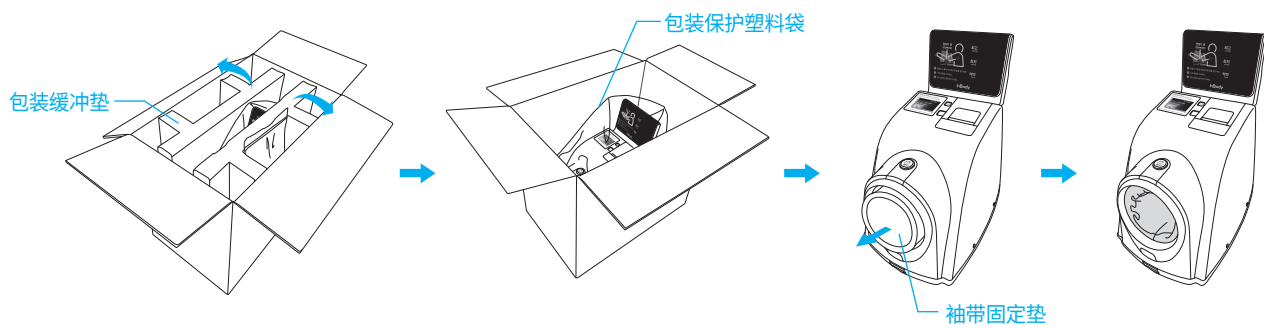

⚠ 注意

- 搬运时请勿单手搬运设备的袖带部分。
- 请保存产品的包装材料，以便日后重新包装时使用。其他废弃物按照当地法规处理。
- 搬运设备时请按照下图所示的方式操作。

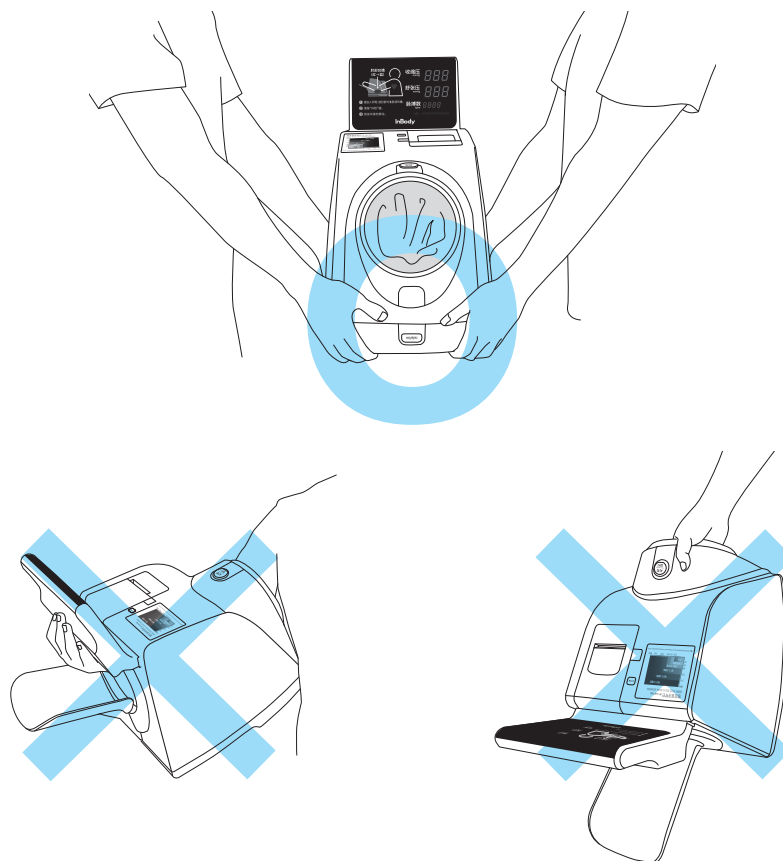

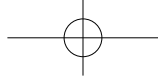

2. 请将BPBIO750放置在可以承受设备重量（7.1kg）的桌面上。

购买BPBIO750专用测试桌时，请将BPBIO750底部的测量桌固定孔与血压测量专用桌上的孔对准后，使用固定螺丝（2个）将血压计与测量专用桌固定。

* BPBIO750专用测试桌是选配件，如有需要请另行购买。

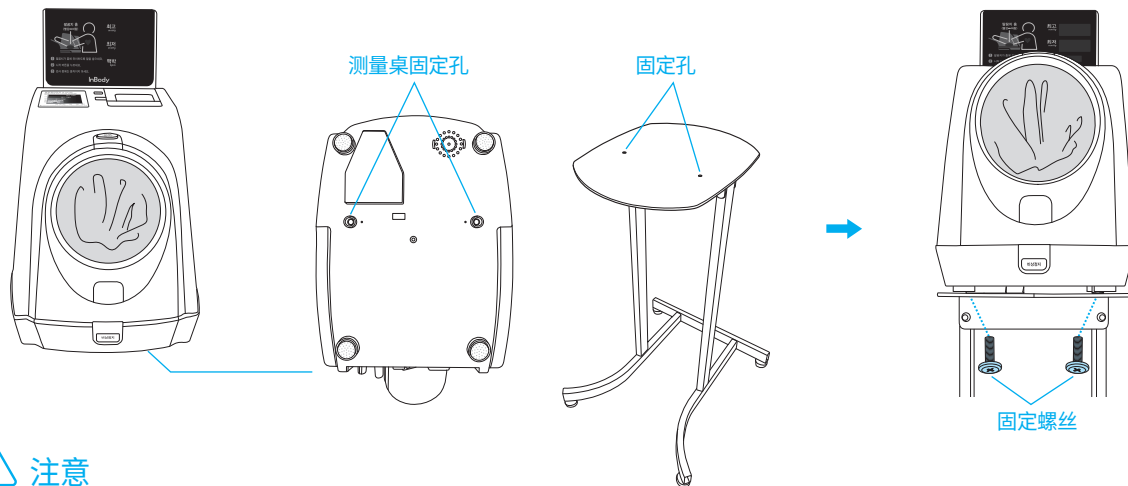

⚠ 注意

- 请将BPBIO750安装在平坦、稳定的台面上。若将产品安装在非平坦的台面上，可能会造成测试过程中摔伤或测试结果不准确。

3. 连接BPBIO750包装箱内的电源线。

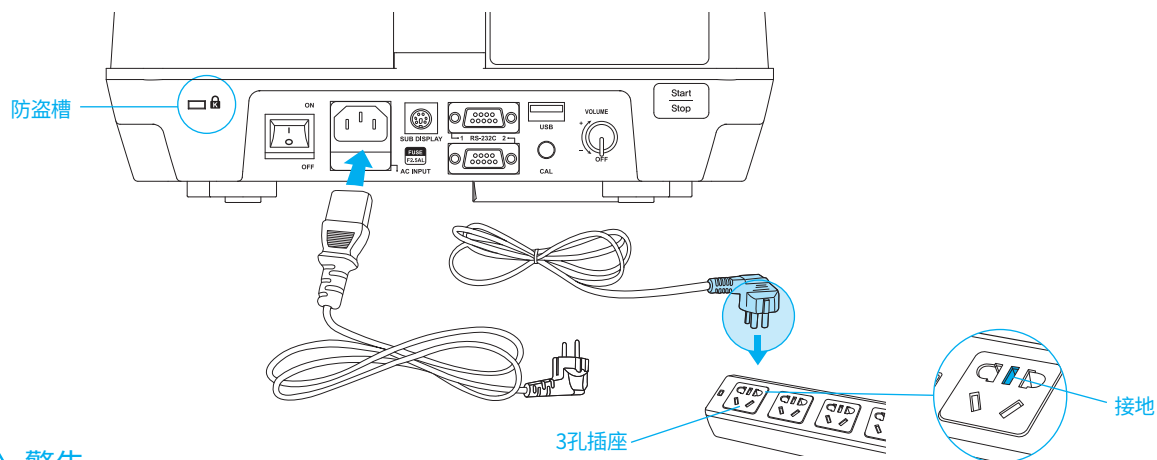

⚠ 警告

- 请勿将设备安装在难以拔插电源线的地方。
- 请勿用潮湿的手拔插电源，会有触电危险。
- 请使用符合规格电源（AC 100-240）的插线板。
- 连接其他电源时可能引发火灾或导致设备故障。
- 使用插线板时，应确保插座或延伸电缆具有足够的承载能力。
- 请勿擅自拆卸设备。擅自拆卸设备可能会引起触电、受伤、设备故障或其他不可预知的结果。并且，擅自拆卸设备将导致保修失效。
- 请勿将连接电源后的BPBIO750与其他电子设备连接。可能有触电危险。
- 为了避免电击的风险，本设备必须仅连接到有保护接地的供电网。

⚠ 注意

- 未连接接地电源时，可能因触电引起受伤或误操作。也可能导致测试结果不准确。
- 请小心使用设备。强烈的外力冲击可能导致设备故障。

4. 可通过使用防盗槽，防止设备丢失。

*请使用笔记本电脑等通用的防盗线缆。

*本设备不配备防盗线缆，请另购。

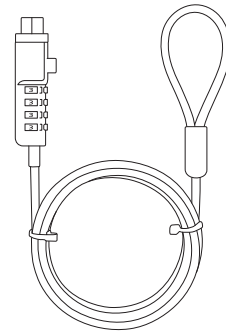

5. 打开BPBIO750背面的电源开关。

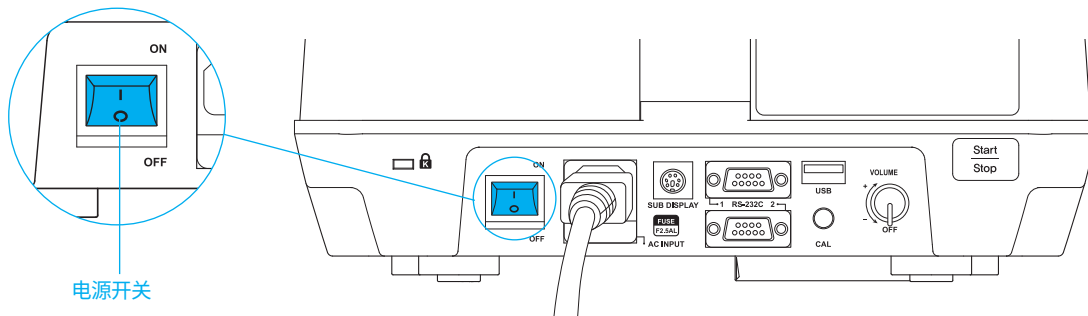

6. 打开电源开关后，出现下图所示界面，BPBIO750会进行自检，确认是否存在异常。

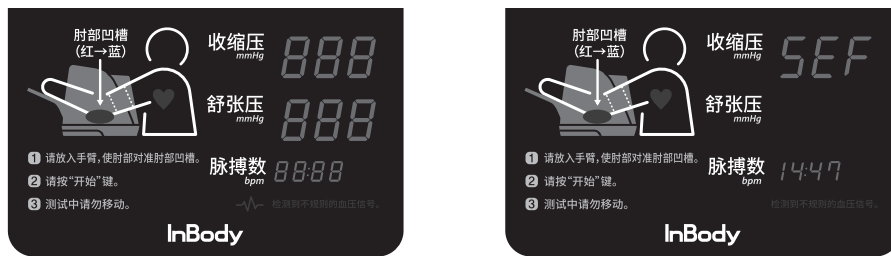

注意

- 在进行自检的过程中（约10秒），请勿操作BPBIO750。
自检过程中操作BPBIO750时，可能导致设备发生错误或自检后血压测试值不准确。

7. 旋转BPBIO750后方的旋钮，调节音量大小。

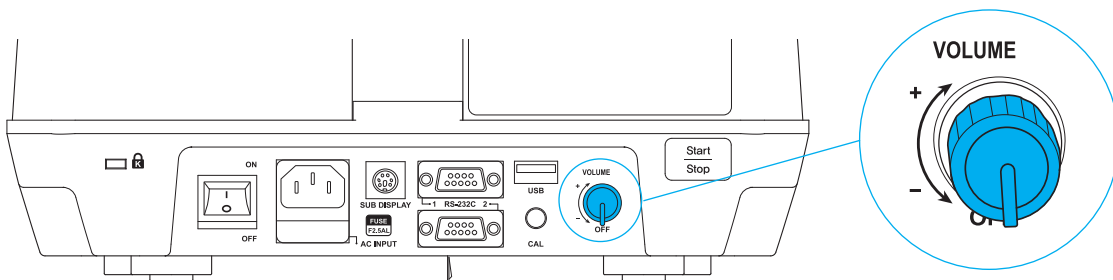



D. 打印纸安装和替换

1. 按下“打印”键下方的按钮，打开打印机盖。

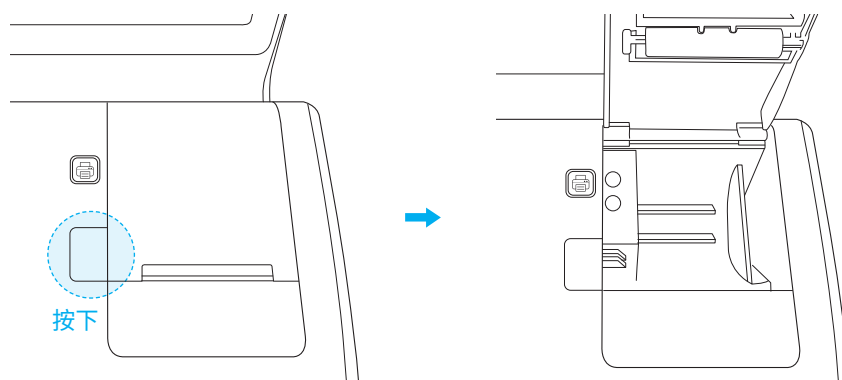

2. 如下图所示，确认热敏打印纸方向后，放入热敏打印纸。放入热敏打印纸后，请将热敏打印纸的部分留在打印机盖外部，然后盖上打印机盖。

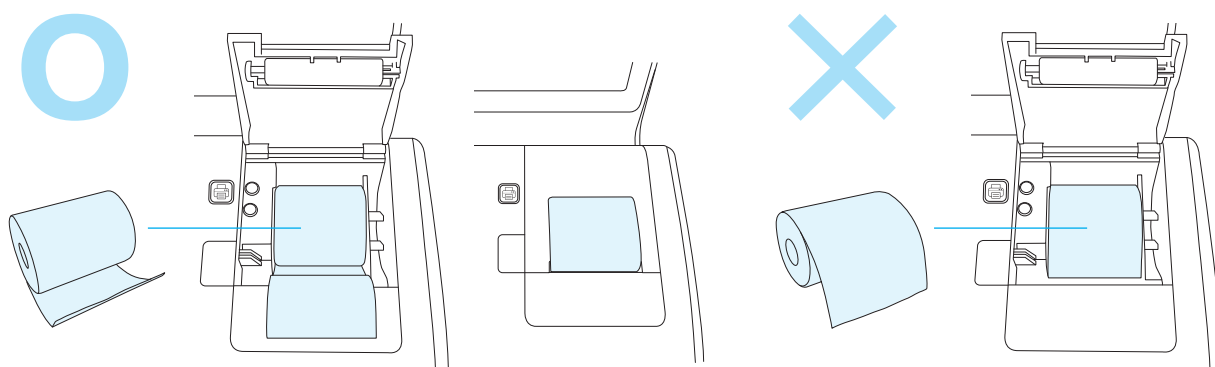

⚠ 注意

- 热敏打印纸方向错误时将无法打印。
- 替换热敏打印纸时，请清除之前的打印纸碎片后再放入新的打印纸。

📖 参考

- 购买BPBIO750时免费提供2卷热敏打印纸。
- 热敏打印纸为消耗品，不足时请另购。



E. 袖带更换

根据BPBIO750袖带的卫生情况，定期更换。

请确认以下事项后，根据说明替换袖带。

1. 将臂部插入口下方的挡盖向下推开，松开螺丝，将正面环扣拉出。

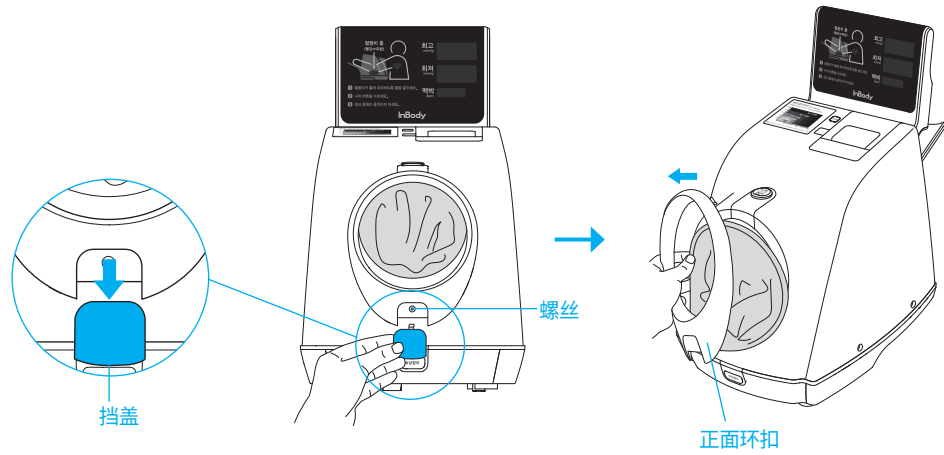

2. 将臂部插入口后方的袖带向内部微微拉扯，分离出来。

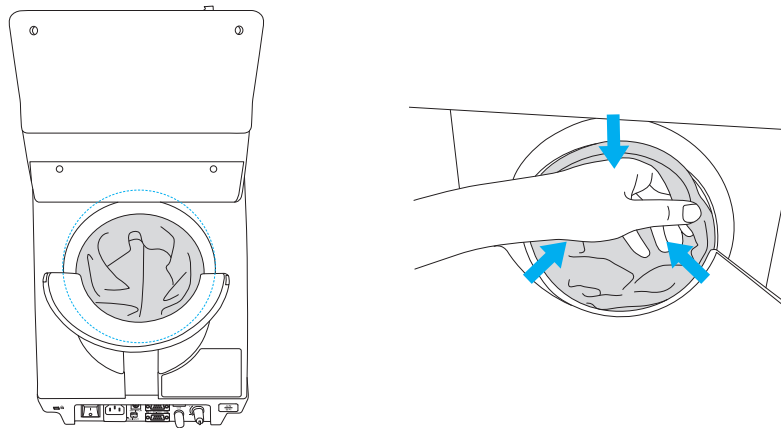

3. 拉出臂部插入口正面的袖带。

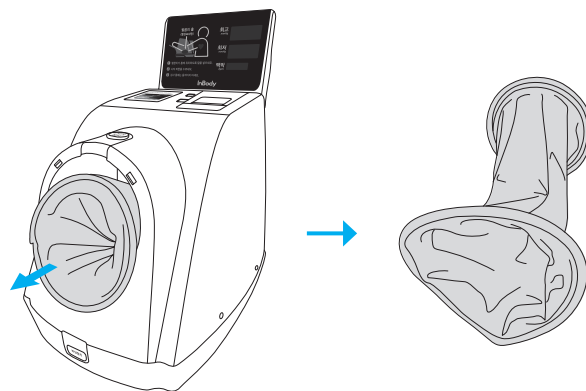



4. 如下图所示，将新袖带缝合线朝下，将袖带环对准正面和后面的环扣插入部，用手按压袖带环，将其固定。

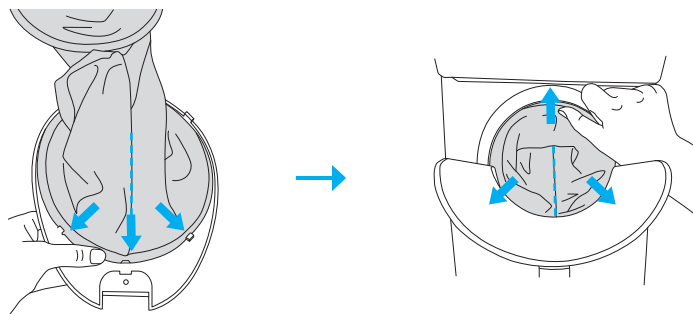

⚠ 注意

- 若未将袖带缝合线朝下，或者标签的部分靠近正面扣环时，可能会导致血压测量结果不准确。

5. 将正面环扣重新安上用螺丝固定，关上挡盖。

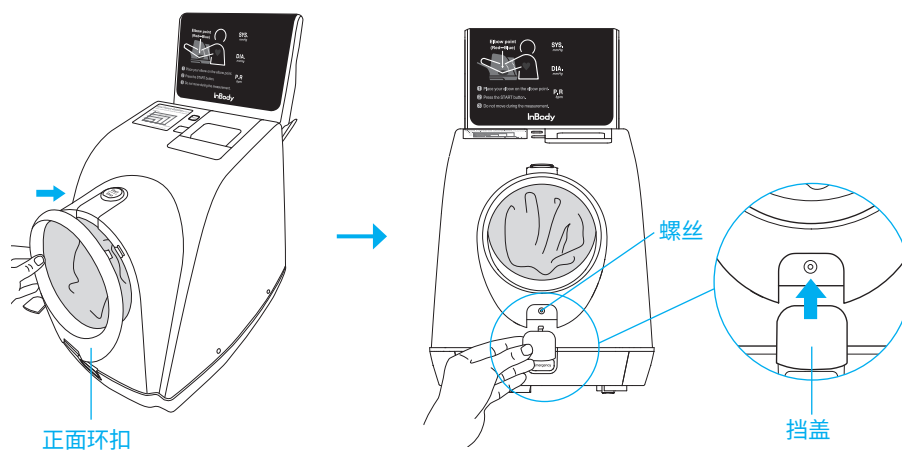

📖 参考

- 购买BPBIO750时免费提供2个袖带。
- 如果以非厂家提供的部件替代原装部件，可能会引起测量错误。
- 袖带为消耗品，不足时请联系生产商或代理商另购。



F. 设置菜单

在设置菜单可进行时/分/年/月/日设置、声音设置、结果报告纸自动打印设置、测试结果显示时间设置、日期打印格式设置、压力单位设置、通信设置、结果报告纸项目设置。

1. 设置菜单进入方法

- 1) 在待机界面同时长按“开始/停止”按钮和“打印”按钮2秒以上，会出现如下所示的设置菜单界面，收缩压栏“F01”（时间设置）闪动，目前设置状态显示在舒张压栏（H0U）与脉搏数栏（时间）。

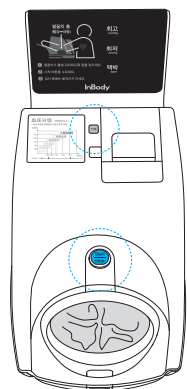

- 2) 在收缩压栏闪动的状态下，可以通过“UP/DOWN”键切换设置项目。

*打开热敏打印机盖后，可看到“UP/DOWN”键。

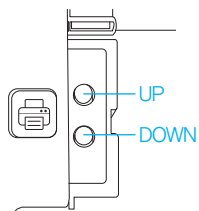

- 3) 选择好需要设置的项目后，按下“开始/停止”键，可切换设置值。

按下“UP/DOWN”键可以切换设置值，该项目的设置值显示在脉搏数栏。

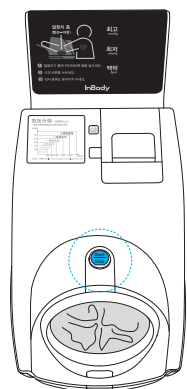

- 4) 设置完成后，按下“开始/停止”键，保存设置信息。保存结束后可以切换到其他设置项目。

- 5) 完成所有项目的设置后，长按“打印”键2秒，回到待机界面。

2. 设置菜单演示

以下是将结果报告纸自动打印改为手动打印的演示。

1) 在待机界面同时长按“开始/停止”键和“打印”键2秒以上。

如下所示出现设置菜单的初始界面“F01”，并能看到当前的设置状态。

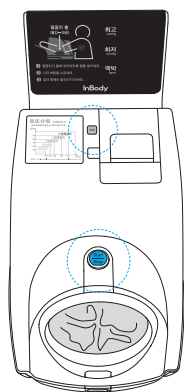

2) 通过“UP/DOWN”键移动到结果报告纸自动打印项目‘F07 Prt’。

脉搏数栏显示当前的设置值‘00’。

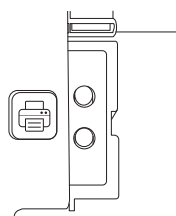

3) 按下“开始/停止”键，进入到该菜单的设置。

通过“UP/DOWN”键，将当前的设置值‘00’切换为‘OFF’。

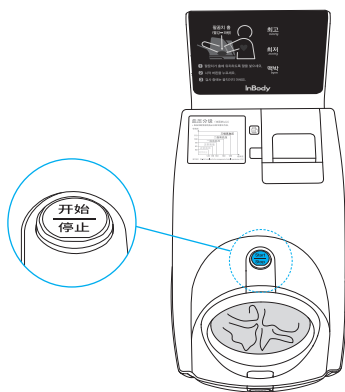

4) 按下“开始/停止”键，保存设置值，从当前项目设置退回到上级设置菜单。

5) 再次确认脉搏数栏内的设置值，完成所有的设置后，长按“打印”键2秒回到待机界面。



3. 设置菜单的详细说明

切入设置菜单后，各项目在收缩压、舒张压、脉搏数栏内显示的内容如下。

功能	界面			说明	
	收缩压	舒张压	脉搏数		
“时”设置	<i>F01</i>	<i>HOU</i>	<i>14</i>	时设置 (0~23)	
“分”设置	<i>F02</i>	<i>MIN</i>	<i>15</i>	分设置 (0~59)	
“年”设置	<i>F03</i>	<i>YER</i>	<i>20 17</i>	年设置 (2000~2035)	
“月”设置	<i>F04</i>	<i>MEH</i>	<i>10</i>	月设置 (1~12)	
“日”设置	<i>F05</i>	<i>DAY</i>	<i>22</i>	日设置 (1~31)	
声音设置	<i>F06</i>	<i>Snd</i>	<i>U01</i>	测量提示+测量结果播报	
			<i>U02</i>	仅测量提示	
			<i>U03</i>	仅测量结果播报	
			<i>bEF</i>	蜂鸣提示音	
			<i>OFF</i>	不使用提示音	
结果报告纸自动打印设置	<i>F07</i>	<i>Prt</i>	<i>ON</i>	结果报告纸自动打印	
			<i>OFF</i>	结果报告纸手动打印	
测试结果显示的时间设置	<i>F08</i>	<i>LCd</i>	<i>05</i>	5秒	
			<i>10</i>	10秒	
			<i>20</i>	20秒	
			<i>30</i>	30秒	
			<i>60</i>	60秒	
			<i>120</i>	120秒	
日期格式设置	<i>F09</i>	<i>dAt</i>	<i>1.Ynd</i>	YY / MM / DD	
			<i>2.ndY</i>	MM / DD / YY	
			<i>3.dnY</i>	DD / MM / YY	
压力单位设置	<i>F10</i>	<i>Un1</i>	<i>1.H9</i>	mmHg	
			<i>2.PA</i>	kPa	
通信设置	<i>F11</i>	<i>232</i>	<i>1.Inb</i>	InBody	
			<i>2.PC</i>	PC	
结果报告纸 项目 设定	结果报告纸格式	<i>F12</i>	<i>For</i>	<i>15nL</i>	纵向3列 (显示较小) *F13~F18不可使用
				<i>2b19</i>	横向排列 (显示较大)
	附加结果值	<i>F13</i>	<i>6oP</i>	<i>ON</i>	输出平均血压/脉压/心率血压乘积
				<i>OFF</i>	不输出
	血压结果图表	<i>F14</i>	<i>9rP</i>	<i>ON</i>	输出美国保健协会标准图表
				<i>OFF</i>	不输出
	检测姿势确认	<i>F15</i>	<i>Arn</i>	<i>ON</i>	输出肘部感应器位置提示
				<i>OFF</i>	不输出

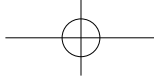

结果报告纸	血压常识	F 16	not	ON	结果报告纸输出血压常识
				OFF	不输出
项目 设定	PULSE图表	F 17	PUL	ON	结果报告纸输出PULSE图表
				OFF	不输出
	LOGO	F 18	Lo9	ON	结果报告纸输出定制LOGO
				OFF	不输出
肘部感应器设置		F 19	SEn	ON	使用肘部感应器
				OFF	不使用
结果报告纸 项目设定	二维码	F 20	qr	ON	打印二维码
				OFF	不打印二维码
测量模式设置	连测3次设置	F 21	Ru9	ON	连测3次模式
				OFF	一般测量模式

“QR码”这一名称为DENSO WAVE INCORPORATED的注册商标。

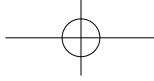

G. 连接InBody人体成分分析仪

BPBIO750连接InBody产品时，血压测量结果将发送给InBody。

- * 请务必连接InBody Co., Ltd. 的产品。
- * 血压结果可以打印在InBody结果报告纸上。
- * 如需9针串口连接线请另行购买。

1. 关于BPBIO750的电源。

- * BPBIO750S开机状态时，可能无法顺利连接InBody其他产品。

2. BPBIO750背部有9针串口，连接线一端连接血压计，一端连接InBody人体成分分析仪。

- * 根据InBody人体成分分析仪的不同型号，9针串口位置也不同，具体请参考各产品使用手册中的说明。

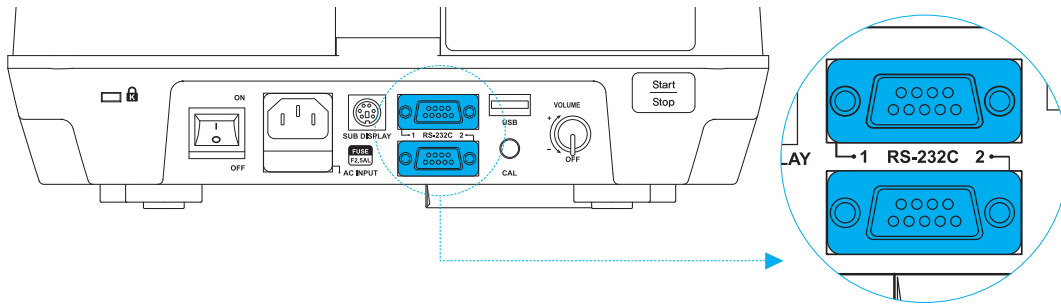

例：InBody 770

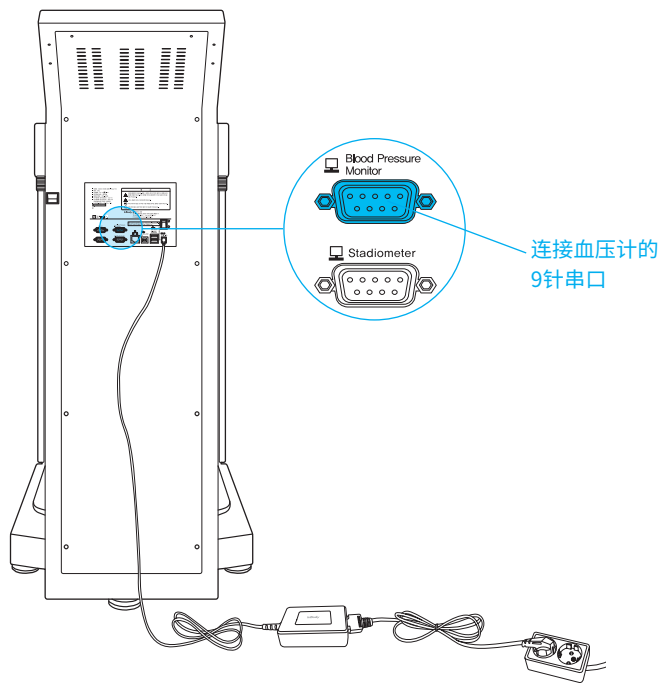

3. 打开BPBIO750电源。

4. 打开InBody设备电源后将自动连接。

参考

- 血压测量结果打印在InBody结果报告纸的方法请参考InBody的使用手册。



H. 维护

注意

- 连接电源的状态下，切勿移动设备。
- 请勿让食物残渣或液体进入设备内部。
- 请每周一次使用软布擦拭设备表面。注意不要划伤LCD屏幕。
- 袖带被污染或破损时，请替换袖带。
- 当有普通心律失常（比如说房早、室早及房颤等）出现时，该设备测量可能会出现误差。
- 如果在规定的温湿度范围外存储或操作使用时，设备测量结果可能会出现误差。
- 当气囊在持久过分充气的状态时，请及时取下袖带，否则可能导致手臂淤血或麻痹。
- 本设备所测的血压值和听诊法的等价，其误差符合YY 0667-2008规定的要求。
- 此血压计的精度已经经过严格测试，建议1年1次对血压计进行检查和校准，以确保血压计功能正常和测量准确。
血压计具备供相关技术部门进行检测的静态压力检测模式，相关信息可拨打客户服务热线咨询。
- 该设备为医用设备，不作为家用产品销售。

在开启电源之前，请确认以下事项：

- 确认设备是否因外力冲击产生变形。
- 确认设备是否被污染。
- 确认设备是否干燥无湿气。
- 确认电源线是否完全插紧牢固。
- 确认电源线是否完好无损。
- 确认电源线摆放位置，避免绊倒跌到。

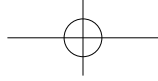

II. 血压测量

A. 测量前注意事项

⚠ 注意

- 建议在测量前休息5-10分钟。
- 请不要卷袖口，最好脱下厚衣服。
- 请将座椅拉至最靠近设备的位置。
- 将胳膊插入袖带，使胳膊肘触碰到肘部凹槽。
- 调整座椅高度，使上臂和心脏高度持平。
- 测量时放松身体并以稳定状态进行测量。
- 测量时，请不要说话或移动。

B. 测量方法

1. 坐下后，调节座椅高度，确保BPBIO750袖带口位置与心脏高度持平。

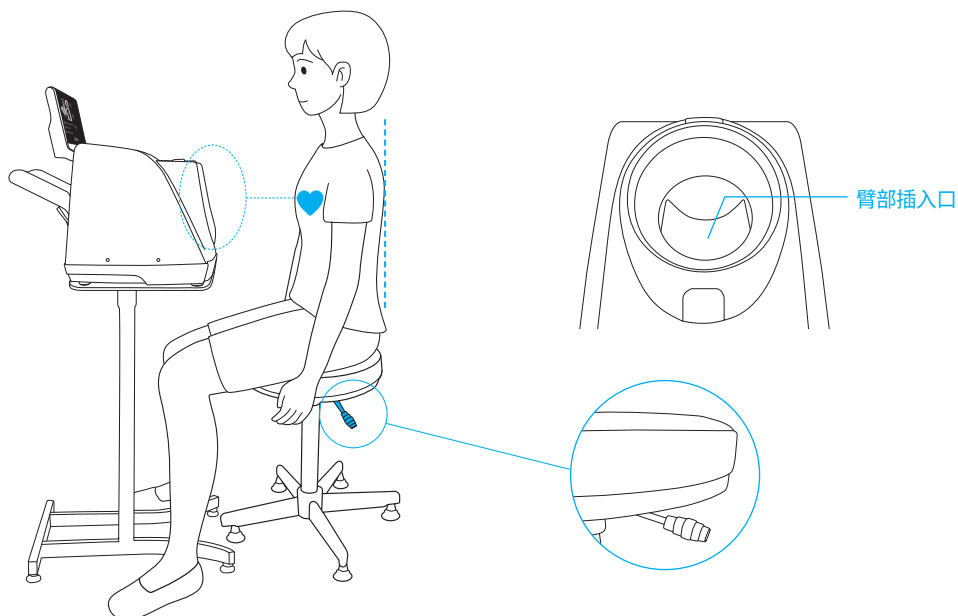

2. 为确保测试值准确，请在测试前休息5分钟以上。

*在不稳定的状态下进行血压测试会导致测试值不准确，大多情况会高于实际血压值。



3. 将臂部插入袖带口，如下图所示，使肘部触碰到肘部凹槽。

*当肘部触碰到凹槽时，屏幕指示图的肘部凹槽蓝色LED灯会亮起。

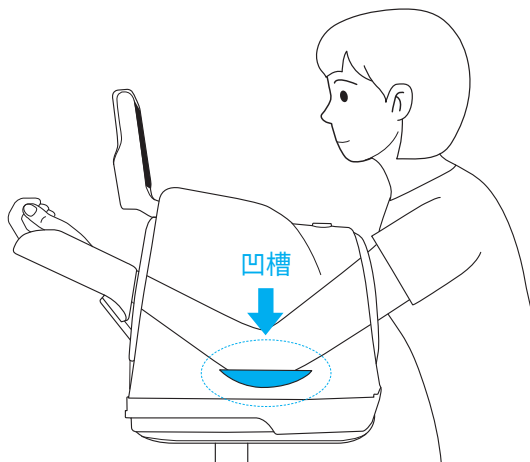

亮起蓝色LED灯

4. 按下“开始/停止”键，开始测量血压。

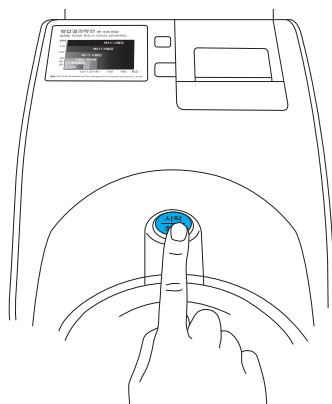

5. 袖带自动加压，逐渐膨胀开始血压测量。

*测试过程中目视前方，请勿说话或移动。
*放松身体，维持准确的测量姿势稍等片刻。

注意

- 血压测量过程中若发生紧急情况可按“**开始/停止**”键,或BPBIO750正面下方的“**紧急停止**”。
- 设备会自动排气，松开袖带。
- 若按键后，设备依旧无法排气，请关闭BPBIO750的电源。

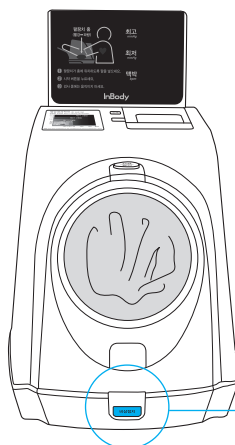

“紧急停止”键



6. 血压测量结束后袖带自动松开。待袖带排气完全结束后再抽出臂部。

7. 通过屏幕可确认结果值。

*根据设置可输出语音提示及结果报告纸。

设置为打印结果报告纸时，热敏打印机会自动切纸，切勿拉扯。



* 可通过BPBIO750的显示屏左侧下方的“血压结果确认”，查看目前血压值的情况。

* 诊断信息请务必以医生意见为准。

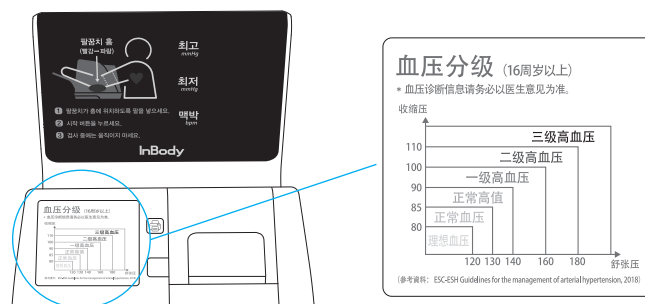

8. 其他

通过BPBIO750背面右侧下方的“开始/停止”键也可对患者进行血压测量的操作，管理人员操作时，可通过该按键更方便地操作。

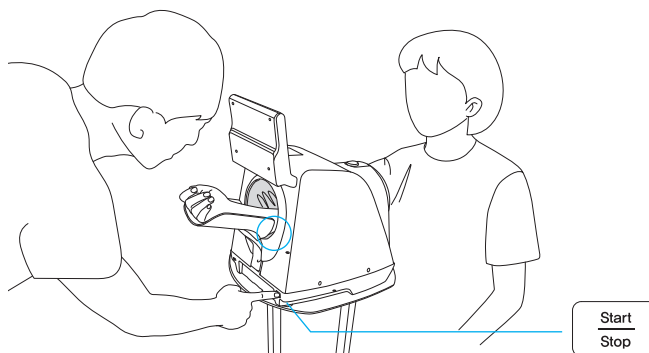

参考

- 若需重复测量血压，请休息5分钟以上之后再次进行。
- 血压根据不同的情况可能产生变化。诊断信息请按照医生意见为准。



C. 测量姿势

请务必按照正确的姿势进行血压测量, 以获得准确的血压数值。

*BPBIO750可用于左臂和右臂的血压测量。

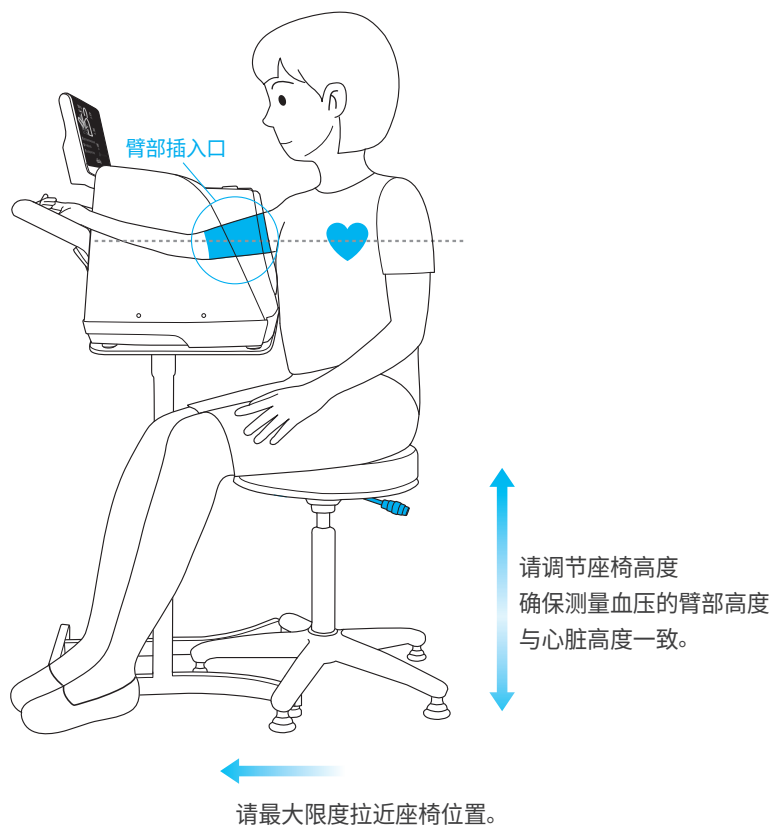

*请将肘部对准肘部凹槽后开始测量。

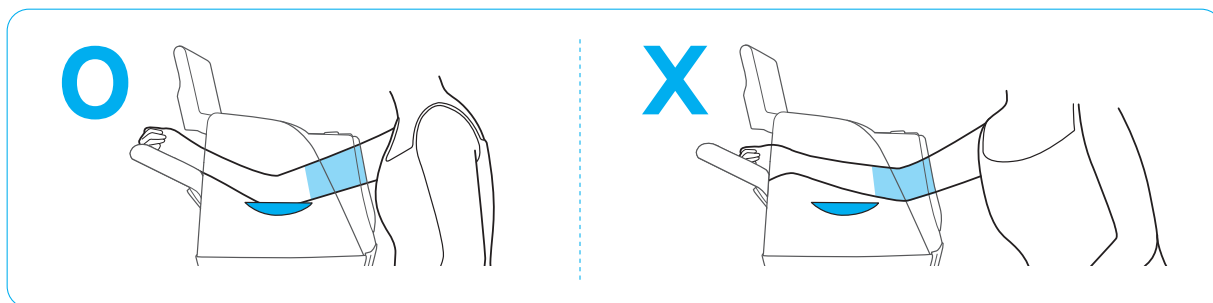

*请脱去厚重外套, 穿轻薄衣物时, 请勿撩起袖子。

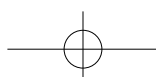
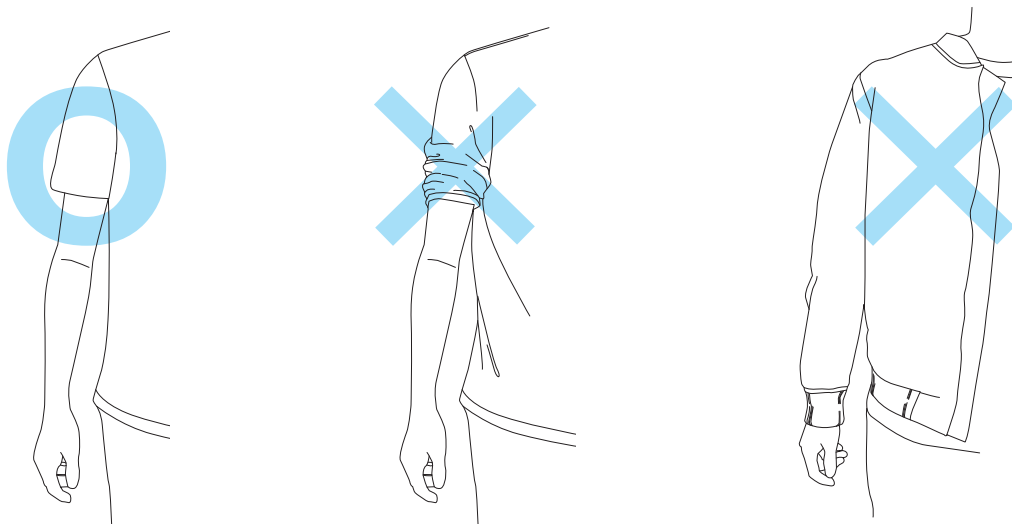

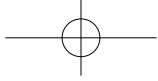

III. 运输和储存

A. 运输注意事项

为安全地搬运BPBIO750，请务必由2名人员，将设备水平搬运。



! 注意

• 若必须由一人搬运设备时，请按照如下方式，水平搬运设备。

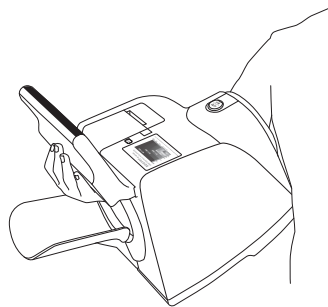
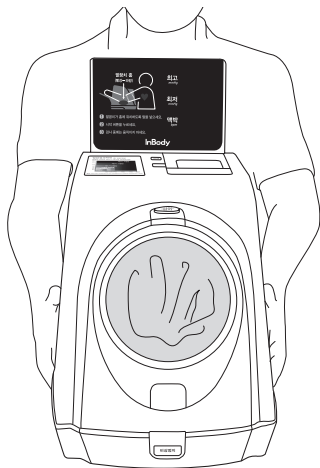

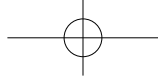

B. 重新包装指南

1. 关闭BPBIO750的电源。
2. 拆下该设备所连接的所有、电源线、电缆，包上保护塑料袋，将设备放入产品包装箱中，盖上缓冲保护垫，封上包装箱。

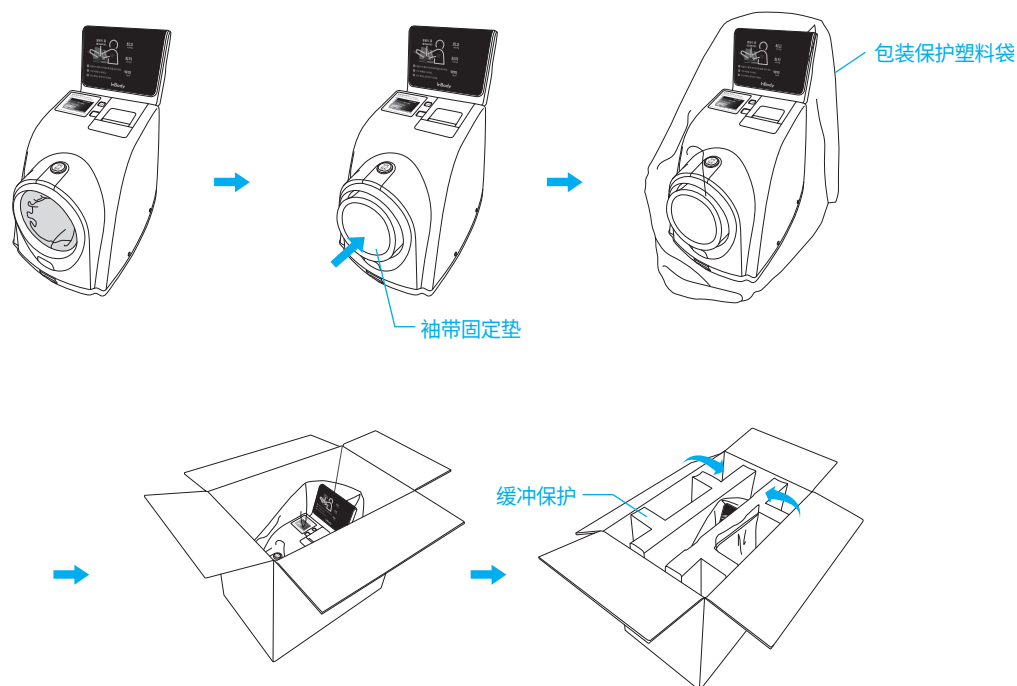

⚠ 注意

- 重新包装时，请务必使用InBody Co., Ltd. 的原装包装材料。

C. 运输及储存环境

BPBIO750的运输及储存应满足以下条件。

温度	-20 ~ 70°C
湿度	10 ~ 93% RH (No Condensation)
气压	50~106kPa

IV. 常见问题解答

关于BPBIO750的常见问题及应对方式如下所示。若根据以下指示仍未解决您的疑问，请联系客服中心。

客服中心：400-888-5363

A. 错误代码

使用过程中发生的异常现象可通过屏幕显示的错误代码确认情况。



请将故障信息告知客服人员，我们将尽快为您解决问题。

B. 关于设备

下列内容是针对确认设备故障的前后顺序，以及假设使用者已经掌握基本使用要领的状态而列出的。

如果在确认并采取措施后仍无法解决问题时，请联系客服中心。

问题	解答
· 无法连接电源。	<ul style="list-style-type: none"> · 请将电源插头完全插入插座中。 
	<ul style="list-style-type: none"> · 使用插线板时，请确认插线板开关已开启。 
	<ul style="list-style-type: none"> · 未使用InBody提供的电源线时可能发生该问题，请务必使用InBody提供的电源线（AC 250V 10A）。 
	<ul style="list-style-type: none"> · 保险丝断开时有可能发生该情况。请按照如下方式替换保险丝。 <ol style="list-style-type: none"> ① 保险丝位于设备后方电源线连接处下方。 ② 如下图所示，在保险丝处插入一字螺丝刀，将保险丝取出。 <p>替换设备包装中备用的保险丝。</p> <p>也可另购。用长条物取出旧的保险丝，再推入新的保险丝即可。</p> 



问题	解答
----	----

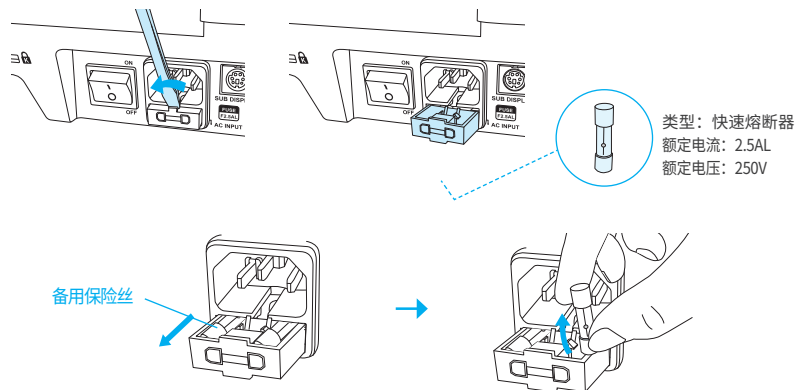

警告

- 替换保险丝时，请务必关闭设备电源。
- 请务必使用规定规格的保险丝。(250V, 2.5A)

• 无法输出提示音。

• 在BPBIO750音量旋钮关闭时可能发生该情况。打开BPBIO750后面的音量旋钮。

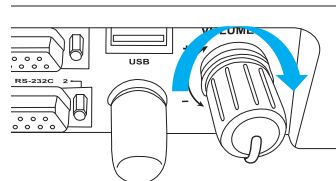

- 声音设置中，设置为仅输出提示音时可能发生该情况。当‘F06’设置为‘4bEP’时仅输出提示音。更改为‘1UD1’后可输出语音。
*请参考第11页的“F. 设置菜单”。

• 无法打印结果报告纸。

- 当设置为不自动输出结果报告纸时可能发生该情况。当‘F07’，自动打印报告纸设置为‘OFF’时，仅可以手动打印结果报告纸。若需自动打印报告指，可将设置更改为‘ON’。
*请参考11页的“F. 设置菜单”。
- 热敏打印纸用尽时可能发生该情况。请打开打印机盒盖，替换热敏打印纸。
- 热敏打印纸方向错误时可能发生该情况。打开热敏打印机盒盖，确认热敏打印纸方向。
- 热敏打印机盒盖未完全关闭时可能发生该情况。请完全关闭热敏打印机盒盖。
*请参考第8页“D. 打印纸安装和替换”。

注意

- 请勿擅自或让非InBody Co., Ltd. 的人员拆解、维修仪器，因此而产生的设备故障及损失，本公司概不负责。

参考

- 如需维修或维护设备，请致电客服中心（400-888-5363）。
- 错误代码、输出异常的报告纸等将作为本公司售后服务的重要资料，请务必妥善保管或保留完整的记录。

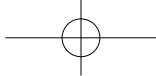

C. 关于血压测量

关于血压测量的疑问及解答如下。

问题	解答
----	----

- 测量结果不准确。

- 血压测量时臂部高度与心脏高度不一致时可能发生该情况。请调节座椅高度，确保大臂高度与心脏高度一致。

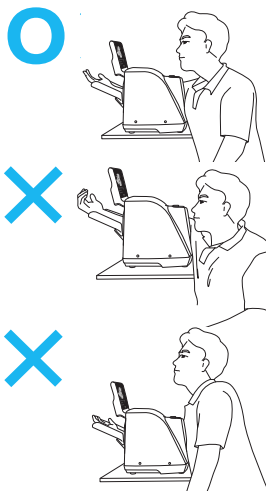

正确的测量姿势，臂部与心脏高度呈水平。

臂部高度比心脏高度高。
血压测量结果会比实际血压值低。

臂部高度比心脏高度低。
血压测量结果会比实际血压值高。

- 臂部插入的袖带过深或过浅时可能发生该情况。请如下图所示，将肘部对准肘部凹槽后开始血压测量。



- 测试时双腿自然弯曲着地，不应翘二郎腿。
- 穿厚重的衣服测量时可能发生该情况。

*血压测量结果会比实际血压值高。
请脱下厚重外套，请勿在撩起袖子的状态下测量血压。

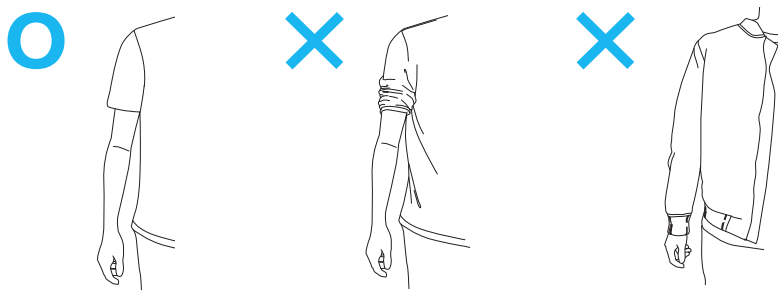

- 未获得充分休息的情况下进行血压测量可能发生该情况。请至少休息5分钟之后再行血压测量。

*即使获得了充分的休息，第一次测量血压的情况仍有可能偏高。请在5分钟之后再次测试。

- 在测量血压过程中移动或说话时可能发生该情况。测量血压过程中请目视前方，在稳定的状态下测量，请不要说话或移动。

*人体血压一天的变化会在30mmHg以上，时时刻刻都在变化。重要的是周期性地、观察持续的血压值，而不应仅看一次的血压测量结果。



问题	解答
----	----

· 血压应在什么时候测量?

· 如下图所示, 人体一天的血压值变化有可能在30mmHg。

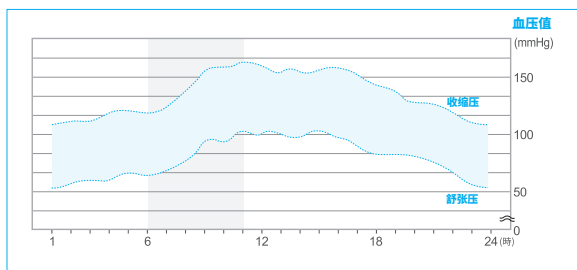

即, 每天固定时间进行血压测量是最为合适的。
建议在每天同一时间, 同一身体状态 (例如空腹状态) 进行血压测量。

· 多测血压没问题吗?

· 电子血压计是通过向臂部施加压力测量血压的。连续测试血压时可能给血管造成过大压力。测量血压1次以上时, 建议每次测量间隔5分钟以上, 充分休息后再进行血压测量。

· 什么情况下不可测量血压?

· 电子血压计是通过向臂部施加压力测量血压的。若臂部采血、注射之后测量血压, 可能会因测量过程中向臂部施加的压力给血管造成不适。建议在采血、注射一小时之后再测量血压。

· 温度环境不同, 测量结果会不一样吗?

· BPBIO750可在5~40°C条件下操作。但受试者根据温度的高低变化, 血管会收缩或扩张, 从而影响血压测量结果。建议选择受试者感觉舒适的温度条件下进行血压测量。
· 在周围吵闹或散漫的环境下进行测试时, 受试者不易处于稳定的状态。建议在较为安静无干扰的环境条件进行血压测量。

· 可导致血压与平时不同的因素有哪些?

· 血压在以下情况下可能发生变化。
1) 进食后1小时以内
2) 饮酒、咖啡、红茶等之后
3) 吸烟后
4) 沐浴后
5) 运动后
6) 排尿、排便后
7) 血压测量场所或环境与平时不同时
建议需要管理血压的患者应在同一时间、同一状态下进行血压测量。

· 家里和医院测量的血压值不一样。

· 血压会根据周围环境变化而变化。建议需要管理血压的患者应在相同的环境条件下进行血压测量。
· 在家测量血压比在医院测量血压更易处于安定的状态。
大部分情况下, 医院测量的血压会比在家测量的血压略高。

V. 其他

* BPBIO750电子血压计根据InBody的质量管理规范进行生产。InBody Co., Ltd. 符合ISO9001和ISO13485国际质量管理体系。

* BPBIO750电子血压计满足医用电气设备安全通用要求以及医用电气设备电磁兼容要求。

A. 外观及功能

BPBIO750各个部分的名称及功能如下。

*安装前请确认各个部分是否有破裂或损坏。

- 1  : 显示结果值，测试引导内容的屏幕
- 2  : 血压结果值确认表
- 3  : 打印测试结果的按键
- 4  : 开始和结束测量的按键
- 5  : 测试过程中发生紧急情况时，用于紧急停止使用的按键
- 6  : 放入热敏打印纸后的盒盖
- 7 8  : 切换系统设置时使用的UP/DOWN按键
- 9  : 打开或关闭设备电源的开关
- 10  : 外部电源输入端口 (100-240V, 50/60Hz) , Fuse (F2.5AL,250V)
- 11  : 与外接屏幕连接的端口
- 12  : RS232C (串口通信) 端口
- 13  : USB端口
- 14  : 校准压力值时连接水银血压计时使用的接口
- 15  : 调节音量的旋钮
- 16  : 背面“开始/停止”键

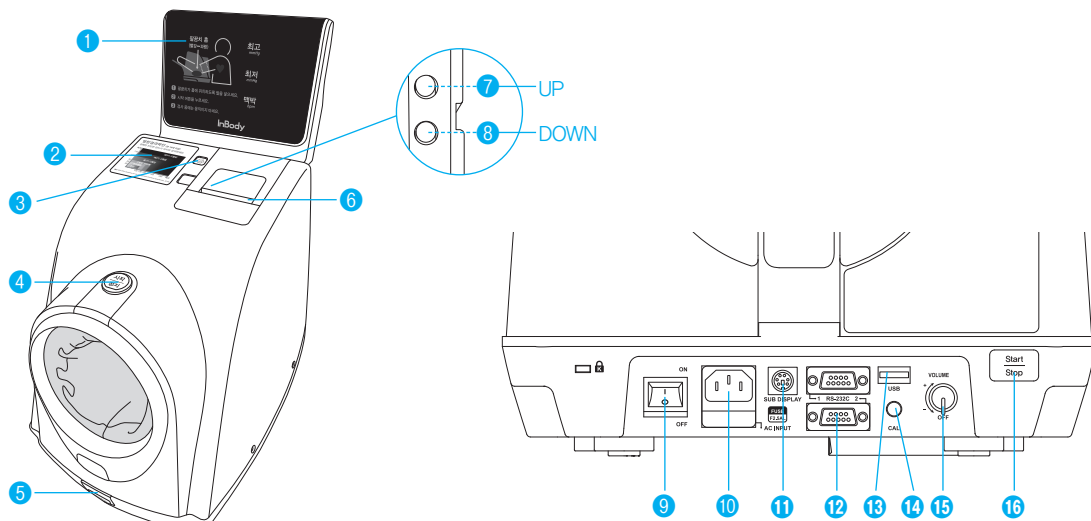





B. 安全信息

安全标记

	高风险电压		警告/小心
	参考		BF型设备
	电源开		电源关

其他标记

	制造商		序列号
	欧洲授权代表		交流电
	CE认证		使用手册



本产品的“环保使用期限”为10年，该环保使用期限是指在正常使用情况下，产品及其附件产品含有的有毒有害物质不会发生外泄或突变，不会对环境造成严重污染或对其人身、财产造成严重损害的期限。

C. 产品分类

运用示波法的多功能电子血压计

- 按防电击类型分类：I类；
- 按防电击程度分类：BF型；
- 按对进液的防护程度分类：IPX0；
- 按在与空气混合的易燃麻醉气或与氧化氮混合的易燃麻醉气情况下使用时的安全程度分类：非AP/APG类；
- 按运行模式分类：连续运行；
- 设备的额定电压和频率：AC 100V-240V,50/60Hz；
- 设备的输入功率：60VA；
- 设备是否具有对除颤放电效应防护的应用部分：不具有；
- 设备是否具有信号输出或输入部分：具有；
- 永久性安装设备或非永久性安装设备：非永久性安装设备。

产品中的有害物质的名称及其含量

部件名称	有害物质					
	铅 (Pb)	汞 (Hg)	镉 (Cd)	六价铬 (Cr ⁶⁺)	多溴联苯 (PBB)	多溴二苯醚 (PBDE)
电路板组件	×	○	○	○	○	○
塑料件	○	○	○	○	○	○
五金件	○	○	○	○	○	○
其他附件	○	○	○	○	○	○

D. EMC声明

- 1) 本章节为电磁兼容性的专门提示。BPBIO750电子血压计应根据本章节的电磁兼容性信息进行安装和使用。
- 2) 便携式和移动式射频通信设备可能影响BPBIO750的使用，在正常使用BPBIO750时，建议远离便携式和移动式射频通信设备或使其处在关闭状态。
- 3) 必须使用由本公司提供的连接电缆。其中，电缆的长度如下：

序号	名称	电缆长度(m)	是否屏蔽
1	电源线(L+N+PE)	1.8	否

- 4) 警示：除本公司提供的附件外，使用其它的厂家附件可能导致BPBIO750发射的增加或抗扰度的降低。
- 5) 电磁发射说明见表1。
- 6) BPBIO750不应该与其工作频率相同或相近的其它设备接近或叠放使用，如果必须接近或叠放使用，则应观察验证在其使用的配置下能正常运行。
- 7) 电磁抗扰度说明见表2。
- 8) 基本性能：无。
- 9) 电磁抗扰度及便携式、移动式射频通信设备和BPBIO750之间的推荐隔离距离见表3和表4。
- 10) 为了保证BPBIO750能够正常使用且保证其发射不被增加和抗扰度不被降低，请选用本公司提供的连接电缆及相关附件。
- 11) 对规定外的附件、换能器或电缆与BPBIO750一起使用，可能导致设备或系统发射的增加或抗扰度的降低。
- 12) 即使其他设备符合相应的国家标准的发射要求，BPBIO750仍可能被其他设备干扰。

表1 指南和制造商的声明——电磁发射

指南和制造商的声明——电磁发射

BPBIO750电子血压计预期在下列规定的电磁环境中使用，购买者或使用者应保证它在这种电磁环境下使用：

发射试验	符合性	电磁环境——指南
射频发射 GB 4824	1组	BPBIO750适于在非家用和与家用住宅公共低压供电网不直接连接的所有设施中使用。
射频发射 GB 4824	A类	
谐波发射 GB 17625.1	不适用	
电压波动/闪烁发射 GB 17625.2	不适用	



表2 指南和制造商的声明——电磁抗扰度

指南和制造商的声明——电磁抗扰度

BPBIO750电子血压计预期在下列规定的电磁环境中使用, 购买者或使用者应保证它在这种电磁环境中使用:

抗扰度试验	IEC 60601 试验电平	符合电平	电磁环境——指南
静电放电 GB/T 17626.2	±6 kV 接触放电 ±8 kV 空气放电	±6 kV 接触放电 ±8 kV 空气放电	地面应是木质、混凝土或瓷砖, 如果地面用合成材料覆盖, 则相对湿度应至少30%
电快速瞬变脉冲群 GB/T 17626.4	±2 kV 对电源线 ±1 kV对输入/输出线	±2 kV 对电源线 不适用	网电源应具有典型的商业或医院环境中使用的质量
浪涌 GB/T 17626.5	±1 kV 线对线 ±2 kV 线对地	±1 kV 线对线 ±2 kV 线对地	网电源应具有典型的商业或医院环境中使用的质量
电源输入线上电压暂降、短时中断和电压变化 GB/T 17626.11	<5% U_T ,持续0.5周期 (在 U_T 上, >95%的暂降) 40% U_T , 持续5周期 (在 U_T 上, 60%的暂降) 70% U_T , 持续25周期 (在 U_T 上, 30%的暂降) <5% U_T ,持续5s (在 U_T 上, >95%的暂降)	<5% U_T ,持续0.5周期 (在 U_T 上, >95%的暂降) 40% U_T , 持续5周期 (在 U_T 上, 60%的暂降) 70% U_T , 持续25周期 (在 U_T 上, 30%的暂降) <5% U_T ,持续5s (在 U_T 上, >95%的暂降)	网电源应具有典型的商业或医院环境中使用的质量。如果BPBIO750的用户在电源中断期间需要连续进行, 则推荐BPBIO750采用不间断电源或电池供电。
工频磁场 (50Hz/60Hz) GB/T 17626.8	3 A/m	3 A/m	工频磁场应具有在典型的商业或医院环境中典型场所的工频磁场水平特性。

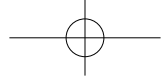
注: U_T 指施加试验电压前的交流网电压。



表3 指南和制造商的声明——电磁抗扰度

指南和制造商的声明——电磁抗扰度

BPBIO750电子血压计预期在下列规定的电磁环境中使用,购买者或使用者应保证它在这种电磁环境中使用:

抗扰度试验	IEC 60601 试验电平	符合电平	电磁环境——指南
射频传导 GB/T 17626.6	3 V(有效值) 150 kHz ~ 80 MHz	[3] V(有效值)	便携式和移动式射频通信设备不应比推荐的隔离距离更靠近BPBIO750的任何部分(包括电缆)使用。该距离应由与发射机频率相应的公式计算。 推荐的隔离距离: $d = 1.2 \sqrt{P}$ $d = 1.2 \sqrt{P}$ 80 MHz~800 MHz $d = 2.3 \sqrt{P}$ 800 MHz~2.5GHz
射频辐射 GB/T 17626.3	3 V/m 80 MHz~ 2.5 GHz	[3] V/m	式中: P——根据发射机制造商提供的发射机最大额定输出功率,单位为瓦特(W); d——推荐的隔离距离,单位为米(m)。 固定式射频发射机的场强通过对电磁场所勘测a来确定,在每个频率范围b都应比符合电平低。 在标记下列符号的设备附件可能出现干扰。 

注1:在80 MHz和800 MHz频率点上,采用较高频段的公式。

注2:这些指南可能不适合所有的情况,电磁传播受建筑物、物体及人体的吸收和反射的影响。

a 固定式发射机,诸如:无线(蜂窝/无绳)电话和地面移动式无线电的基站、业务无线电、调幅和调频无线电广播以及电视广播等,其场强在理论上都不能准确预知。为评定固定式射频发射机的电磁环境,应考虑电磁场所的勘测。如果测得BPBIO750所处场所的场强高于上述适用的射频符合电平,则应观测BPBIO750以验证其能正常运行。如果观测到不正常性能,则可能需要补充措施,比如重新调整BPBIO750的方向或位置。

b 在150 kHz ~ 80 MHz 整个频率范围,场强应低于[3] V/m。

表4 便携式及移动式射频通信设备和BPBIO750之间的推荐隔离距离

便携式及移动式射频通信设备和BPBIO750之间的推荐隔离距离

BPBIO750电子血压计预期在射频辐射骚扰受控的电磁环境中使用。依据通信设备最大输出功率，购买者或使用者可通过维持便携式及移动式射频通信设备(发射机)和BPBIO750之间最小距离来防止电磁干扰。

发射机最大额定输出功率 W	对应发射机不同频率的隔离距离 / m		
	150 kHz~ 80 MHz $d = 1.2 \sqrt{P}$	80 MHz~ 800MHz $d = 1.2 \sqrt{P}$	800 MHz~ 2.5GHz $d = 1.2 \sqrt{P}$
0.01	0.12	0.12	0.23
0.1	0.38	0.38	0.73
1	1.2	1.2	2.3
10	3.8	3.8	7.3
100	12	12	23

对于上表未列出的发射机最大额定输出功率，推荐隔离距离d，以米(m)为单位，可用相应发射机频率栏中的公式来确定，这里P是由发射机制造商提供的发射机最大额定输出功率，以瓦特(W)为单位。

注1：在80 MHz和800 MHz频率点上，采用较高频段的公式。

注2：这些指南可能不适合所有的情况，电磁传播受建筑物、物体及人体的吸收和反射的影响。



E. 规格

测量方式	示波法(Oscillometric)
测量范围	压力: 0 ~ 300 mmHg 脉搏: 30 ~ 240 bpm
误差范围	压力: ±2mmHg 脉搏: ±1.5%以内
测量结果	收缩压、舒张压、脉搏数、脉压、平均血压、心率血压乘积
测量时间	平均约30秒 (根据脉搏数及血压值20~50秒)
加压时间	10秒
最小测量单位	1mmHg
显示屏幕	7段式 LED
结果报告纸输出	结果值、血压图标、血压常识、PULSE图表、其他提示内容
储存功能	最多可储存100万次测试
自动节能	最后一次测量且无任何后续操作, 2分钟后将自动切换到节能模式
安全装置	按紧急按钮可自动解开袖套和排气 (导入了双重安全装置, 按“紧急停止”时, 与中央控制器无关, 可解开袖套并排气) 按“开始/结束”键, 可迅速解开袖套并排气
语音提示	血压测量提示, 测量后结果提示
打印机	自动切割的高速打印机 (宽: 2.5英寸)
额定电压及功率	AC 100V-240V, 50/60Hz, 60VA
设备尺寸	约 299(W) × 547(D) × 485(H) mm
设备重量	约7.1kg
操作环境	温度 10 ~ 40°C, 湿度 30% ~ 75%RH, 气压 70 ~ 106kPa
储存运输环境	温度 -20 ~ 70°C, 湿度 10 ~ 93%RH, 气压 50 ~ 106kPa

* 生产商保留更改产品规格的权利, 恕不另行通知。



合格证

产品名：BPBIO750电子血压计

序列号：

购买时间：

购买时间：

■本合格证对InBody的产品做出如下保证

1. 本产品经过严格的品质检查是合格的产品。
2. 本产品的保修期以制造商的保修期规定为准。
3. 保修期内正常使用仪器的情况下出现故障给予免费维修。
4. 以下几种情况，即使在保修期内也需要收取维修服务费。
 - 因处理不当引起的故障及损坏
 - 不按说明书的内容操作或不遵守注意事项引起的仪器故障及损坏
 - 自然灾害引起的机器故障及损坏
 - 由于电源异常引起的故障及损坏
5. 以下几种情况引起的仪器故障及损坏将不给予免费维修。
 - 私自拆卸BPBIO750电子血压计
 - 随意更换设备零部件
 - 让非本公司维修人员维修仪器
6. 保修期过后，客户需要维修服务会一律按照公司维修服务费规定来收费。如仪器发生故障或损坏时，请联系InBody China售后服务中心：400-888-5363

InBody



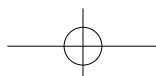
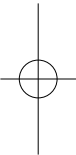
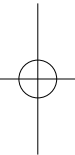

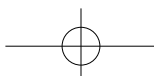
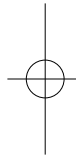
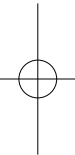

InBody

For product support or clinical questions, please contact us at the following:

InBody Co., Ltd. [HEAD OFFICE]

InBody Bldg., 625, Eonju-ro, Gangnam-gu, Seoul 06106 KOREA

TEL: +82-2-501-3939 FAX: +82-2-578-5669

Website: inbody.com E-mail: info@inbody.com

©2021 InBody Co., Ltd. All rights reserved.

Reproduction, adaptation, or translation of this manual is prohibited without prior written consent from InBody Co., Ltd. under the copyright laws. This user manual may be printed incorrectly and subject to change without notice. InBody Co., Ltd. shall not be liable for any errors, incidental, or consequential damages that occurred by not complying with the content of the User's Manual.

Visit our website (inbody.com) to view and download further information about the functions of the BPBIO750, results interpretation, and more. InBody Co., Ltd. reserves the right to modify the appearance, specifications, etc. of this product to improve its quality or performance without prior notice.

Representative & Sponsor Information

InBody Europe B.V.

Gyroscoopweg 122, 1042 AZ, Amsterdam, The Netherlands

TEL: +31-20-238-6080 FAX: +31-6-5734-1858 Website: nl.inbody.com E-mail: info.eu@inbody.com

Customer Service Information

InBody USA [USA]

13850 Cerritos Corporate Dr. Unit C Cerritos, CA 90703 USA

TEL: +1-323-932-6503 FAX: +1-323-952-5009 Website: inbody.com E-mail: info.us@inbody.com

InBody Co., Ltd. (殷巴迪有限公司)[注册人]

注册人地址: InBody Bldg., 625, Eonju-ro, Gangnam-gu, Seoul, KOREA

生产地址: 15, Heugam-gil, Ipjang-myeon, Seobuk-gu, Cheonan-si, Chungcheongnam-do, 31025 KOREA

生产许可证编号: 第644号

电话: +82-2-501-3939 传真: +82-2-578-5669

网站: inbody.com 电子邮箱: info@inbody.com

拜斯倍斯医疗器械贸易(上海)有限公司[代理人及售后服务]

代理人地址: 上海市闵行区宜山路1698号903、904室

电话: +86-21-6443-9705 传真: +86-21-6443-9706

网站: inbody.com 电子邮箱: info@inbodychina.com

根据法律, 禁止在未经过InBody Co., Ltd.允许的任何条件下对本手册复印、修改与翻译。该手册中存在的任何打印错误可在未经本公司允许的条件下修改。由于不遵循本手册的操作而导致的任何故障、连带后果或间接损失, InBody Co., Ltd.对此不承担任何责任。如需任何关于BPBIO750电子血压计的其他信息, 请登录官网inbody.com查阅并下载。

InBody Co., Ltd. 保留在对产品外观和规格等进行修改以提升产品质量的权利, 恕不另行通知。

InBody Asia [ASIA]

Unit 3A-11, Oval Damansara, 685 Jalan Damansara Kuala Lumpur, WP KL 60000 Malaysia

TEL: +60-3-7732-0790 FAX: +60-3-7733-0790 Website: inbodyasia.com E-mail: info@inbodyasia.com

InBody India [INDIA]

Unit No. G-B 10, Ground Floor, Art Guild House, Phoenix Market City, L.B.S. Marg, Kurla (West), Mumbai 400070 India

TEL: +91-22-6223-1911 Website: inbody.in E-mail: india@inbody.com

Australian Sponsor. [AUSTRALIA]

Emergo AUSTRALIA. Level 20, Tower II, Darling Park, 201 Sussex Street, Sydney, NSW 2000, AUSTRALIA

TEL: +61-2-9006-1662 FAX: +61-2-9006-1010 Website: emergogroup.com E-mail: Sponsor@emergogroup.com

InBody Japan [JAPAN]

Tani Bldg., 1-28-6, Kameido, Koto-ku, Tokyo 136-0071 Japan

TEL: +81-3-5875-5780 FAX: +81-3-5875-5781 Website: www.inbody.co.jp E-mail: inbody@inbody.co.jp

©2021 InBody Co., Ltd. All rights reserved.

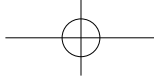

inbody.com

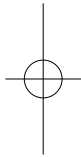
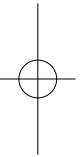

CE 1639

©2021 InBody Co., Ltd. All rights reserved. IM-H2-F-210517

